

RFP for up-gradation of Campus Wide Network at IIM, Raipur



भारतीय प्रबंध संस्थान रायपुर
Indian Institute of Management Raipur



Atal Nagar P. O. - Kurru, Abhanpur, Chhattisgarh - 493661

Telephone: +91-771-2474600

Mail-ID: itdept@iimraipur.ac.in

Web Portal: www.iimraipur.ac.in

Tender Ref. No.: IIMR/Tender/2024-25/06/01 dated 07.06.2024

Table of Contents:

Sno	Description	Page No.
01	Notice Inviting Tender	05
02	Instructions to the Bidders	07
03	Eligibility Criteria	09
3.1	OEM Criteria for Active Components:	10
3.2	OEM Criteria for Passive Components:	11
04	RFP Background	12
4.1	Overview of the Existing Network Setup and Challenges:	13
4.2	Proposed Solution to overcome existing challenges:	14
4.3	Requirements at IIM Raipur Site	16
05	Scope of Work	18
5.1	Proposed BOQ of Active Components:	23
5.2	Proposed BOQ of Passive Components:	24
5.3	Call Flow and Escalation Matrix - Operations & Maintenance	25
5.4	Training	25
06	TECHNICAL SPECIFICATIONS	26
6.1	ACTIVE COMPONENTS	27
6.1.1	Wireless Controller	27
6.1.2	WiFi-6 Indoor Access Points Type I	29
6.1.3	WiFi-6 Indoor Access Points Type II	30
6.1.4	WiFi-6 Indoor Access Points Type III	32
6.1.5	48-Ports Core Switch	33
6.1.6	Access Switch - 12 Ports PoE	35
6.1.7	Access Switch - 12 Ports NonPoE	36
6.1.8	Access Switch - 24 Ports PoE	37
6.1.9	Access Switch - 24 Ports Non - PoE	39
6.1.10	Access Switch - 48 Ports PoE	41
6.1.11	Access Switch - 24 Ports Multigig PoE – Type I	42

6.1.12	Access Switch - 24 Ports Multigig PoE – Type II	43
6.1.13	Access Switch - 48 Ports Multigig PoE	44
6.1.14	10G SM Transceiver	46
6.1.15	NMS	47
6.1.16	Server	49
6.2	PASSIVE COMPONENTS	51
6.2.1	CAT6A UTP Outdoor Jelly Filled Double Jacketed CABLE	52
6.2.2	CAT6A U/UTP LSZH CABLE	54
6.2.3	Cat6A Unshielded Modular Jack	56
6.2.4	Cat 6A Unshielded Patch Cords, LSZH, ETL Tested	57
6.2.5	Face Plate, UK Style, Square with Shutters	58
6.2.6	24 Port CAT 6A Patch Panel	59
6.2.7	6 / 12/24 Core Singlemode (9/125µm) G657-A1 Bend Insensitive Fibre optic Cable	60
6.2.8	24/48Fiber 1U Rack Mount Fiber Enclosure (LIU), Splice Trays and Adapter	61
6.2.9	Fiber Patch Cords, LC-LC / SC-LC / SC-SC Duplex, Singlemode OS2, 3MT	62
6.2.10	Pigtail, LC/SC Type, Single mode OS2, 2 MT	63
07	Terms & Conditions of Contract	64
7.1	Arbitration	64
7.2	Special Terms and Condition:	64
7.3	Clarification of Offers	64
7.4	Extension of Delivery Period and Liquidated Damages	64
7.5	Liquidated Damages	64
7.6	Force Majeure Conditions	64
08	Bid Evaluation	65
8.1	Final Selection and Award of Work	67
09	Delivery and Installation Conditions	68
10	AMC and Warranty Support for LAN Infrastructure	68
11	Comprehensive Warranty Support Services & SLA	69
11.1	Service Level Agreement	70
11.2	Category of SLAs	70

11.3	Penalty for breach of SLA	70
11.4	Escalation and Notifications:	71
11.5	SLA Review Process	71
12	Acceptance Criteria for the Proposed Solution	72
13	Delivery Schedule	74
14	Checklist of the Document to be Submitted with Technical Bid in duly filled formats and signed	75
15	Annexures	78
	Annexure-I	79
	Annexure-II	80
	Annexure-III	81
	Annexure-IV	82
	Annexure V	83
	Annexure VI	84
	Annexure-VII	85
	Annexure-VIII	86
	Annexure IX	87
	Annexure X	92
	Annexure XI	93
	Annexure XII	94
	Annexure XIII	95
	Annexure XIV	96
	Annexure XV	97
	FINANCIAL BID	98
	Annexure XVI	108

1. Notice Inviting Tender

N.I.T. No.: IIMR/Tender/2024-25/06/01

Date: 07.06.2024

Indian Institute of Management (IIM), Raipur invites bids in two bid systems from reputed, experienced and financially sound IT Firm for the following IT Services

Name of Work	Supply, Installation, Testing & Commissioning of Campus LAN upgradation including Passive Lan cabling, network switches & Wi-Fi Setup
Tender Type	Open tender
The Currency in which payment shall be made	Indian Rupees (INR)
Bid Submission Start Date and Time	07.06.2024 from 03:30 pm
Bid Submission Close Date and Time	28.06.2024 at 03:30 pm
Details of Pre-Bid Meeting and Time	Online Link: https://zoom.us/j/6237741074?pwd=UIRReVI3RTB5czNPVU1ZUmN2NFhVUT09 Meeting ID:623 774 1074 Passcode:707731 Tentative: Date: 17.06.2024 Time: 03:30 pm Note: Pre-bid Meeting will be held though online mode only through zoom
Bid queries should reached by	Bidders are requested to send their pre-bid queries on or before 14.06.2024 at email id itdept@iimraipur.ac.in duly mentioning the subject name pre-bid query & tender no. IIMR/Tender/2024-25/06/01 dt.07.06.2024. After the due date no queries will be entertained. Replies to the queries will be made on pre-bid meeting and the replies will also be available on CPP portal and the Institute website on or before 18.06.2024
Date and Time of Opening of Technical Bids	01.07.2024 at 03:30 pm
Technical Presentation	To be informed later
Date and Time of Opening of Financial Bids	Will be opened online through CPP portal
Earnest Money Deposit	Rs.28,00,000.00 (Rupees Twenty-Eight Lacs Only)
No. of Covers	02 (Two Packets)
Bid Validity	120 Days
Performance Bank Guarantee (PBG)	The selected bidder shall be required to submit the Performance Bank Guarantee (PBG) equivalent to 5% of the total work order (WO) value. PBG shall be from any scheduled commercial bank in the name of IIM Raipur for a period of the contract/WO duration plus 6 additional months. PBG is required to be submitted within 15 days from the date of issue of work order.
Purchaser and Place of delivery	Bills to be submitted to IIM Raipur . Successful Bidder shall be responsible for Design, Supply, Installation, Testing & Commissioning of LAN cabling, network switches, Wi-Fi setup for IIM Raipur, Atal Nagar P.O. - Kurru, Abhanpur, Chhattisgarh-493661 as per the scope of work mentioned in the tender document.

1. This is an open tender. Consortium/JV bids are not allowed.
2. Tender shall be available on CPP portal link available at <https://eprocure.gov.in/eprocure/app> or IIM Raipur website <https://iimraipur.ac.in/>. Interested Bidders are advised to go through instructions provided at “Instructions to Bidders for e-tendering.”
3. No manual bids shall be accepted. All bids (both Technical and Financial) should be submitted in the online portal.
4. Bidders are advised to visit the CPP portal for getting themselves updated for information on this tender. Corrigendum, if any may be issued on the changes required. Reply on pre-bid queries received by IIM Raipur shall be displayed on tendering portal. Bidders are advised to visit the webpage regularly and update themselves. The Pre-Bid queries, Corrigendum are part of tender document and Bidders are supposed to upload the same accordingly, duly signed as per the guidelines given in the tender document.

**Chief Administrative Officer.
Indian Institute of Management, Raipur
Atal Nagar P. O. - Kurru, Abhanpur,
Chhattisgarh 493661**

2. Instructions to the Bidders

2.1 Invitation of Bid

- a) IIM Raipur invites responses (“Tenders”) to this Request for Proposal (“RFP”) from OEMs or their authorized Partners (“Bidders”) for the provision of items as described in this RFP for Supply, Installation and commissioning of campus wide network upgradation including LAN cabling, network switches and replacement of existing Wi-Fi setup.
- b) Proposals must be submitted online
- c) through CPP portal before the due date and time of submission.

2.2 General

- a) While effort has been made to provide the accurate background information and requirements and specifications, Bidders must form their own conclusions about the solution needed to meet the requirements.
- b) All information supplied by Bidders may be treated as contractually binding on the bidders, on successful award of the assignment by IIM Raipur on the basis of this RFP.
- c) No commitment of any kind, contractual or otherwise shall exist unless and until a formal written contract has been executed by IIM Raipur.

2.3 Compliant Proposals/ Completeness of Response

- a) Bidders are advised to study all instructions, forms, terms, requirements and other information in the tender documents carefully. Submission of the bid shall be deemed to have been done after careful study and examination of the tender document with full understanding of its implications.
- b) Failure to comply with the requirements set out in this Tender may render the Proposal noncompliant and the Proposal may be rejected. Bidders must:
 - i. Include all documentation specified in this Tender;
 - ii. Follow the format of this tender and respond to each element in the order as set out in this tender.
 - iii. Comply with all requirements as set out within this tender.

2.4 Pre-bid Meeting

- a) IIM Raipur shall hold a pre-bid meeting with the prospective bidders via video conferencing on <https://zoom.us/j/6237741074?pwd=UIRReVI3RTB5czNPVU1ZUmN2NFhVUT09>
Meeting ID:623 774 1074
Passcode:707731
Tentative: Date: 14.06.2024
Time: 03:30 pm
- b) The Bidders will have to ensure that their queries for Pre-Bid meeting should reach the IT Dept. by email : itdept@iimraipur.ac.in with a copy to sysmgr@iimraipur.ac.in on or before 14.06.2024 till 05:30 pm. The queries should necessarily be submitted as per the format (Annexure-XI)
- c) IIM Raipur shall not be responsible for ensuring receipt of the bidders’ queries. Any requests for clarifications post the indicated date and time may not be entertained by IIM Raipur.

2.5 Key Requirements of the Bid

- a) This tender does not constitute an offer by IIM Raipur. The bidder’s participation in this process may result in selecting the bidder to engage towards execution of the contract.

2.6 Earnest Money Deposit (EMD)

- a) Bidders shall submit, along with their Bid an EMD of INR.28,00,000.00 may be furnished electronically or in the shape of Demand Draft OR Bank Guarantee issued by any scheduled bank in favor of IIM Raipur. In the case of EMD submitted through Bank Guarantee, it should be valid for 120 days from the due date of the tender.
- b) EMD of all unsuccessful bidders would be refunded within 30 days of finalization of tender or within 15 days after award of work to selected bidder, whichever is earlier. The EMD for the amount mentioned above, of successful bidder would be returned upon submission of Performance Bank Guarantee.
- c) The EMD amount is interest free and will be refundable to the unsuccessful bidders without any accrued interest on it.
- d) The bid / proposal submitted without EMD, mentioned above, will be summarily rejected.
- e) The EMD may be forfeited:
 - If a bidder withdraws its bid during the period of bid validity.
 - In case of a successful bidder, if the bidder fails to sign the contract in accordance with this RFP.
 - If found to have a record of poor performance such as having abandoned work, having been blacklisted, having inordinately delayed completion and having faced Commercial failures etc.
 - The Bidder being found to have indulged in any suppression of facts, furnishing of fraudulent statement, misconduct, or other dishonest or other ethically improper activity, in relation to this RFP

2.7 Submission of Manufacturer Authorization letter

- a) Bid specific Manufacturer Authorization Form (MAF) as per format (Annexure X) should be submitted along with, while submitting the response to RFP failing which the bid is subject to rejection.
- b) The Bidder(s) must submit the technical compliances on their letterhead along with the Datasheet of the equipment quoted.
- c) OEM qualification criteria is not required for Racks, but bidder has to ensure that the rack OEM should be ISO certified (latest) and should provide make / model no. along with supporting documentation.
- d) For ducts, conduits, pipe and accessories MAF is not required, however make and model needs to be specified.

2.8 Domestic Manufacturer Clause

- a) Supplier must submit an undertaking on notarized Rs. 100/- stamp paper, providing the information as specified in Annexure xvi. The Supplier also need to specify the category it belongs to. This is in compliance with Order No. P-45021/2/2017-PP (BE - II), Ministry of Commerce & Industries (DPIIT) dt. 4th June 2020 or modified time to time.

Eligibility Criteria

- a. The bidder should be either an OEM (or) a business partner / channel partner / system integrator duly authorized by the respective OEMs of active & passive components to quote for this tender.
- b. **Experience Criteria:** The Bidder must have successfully executed the similar projects including LAN cabling and active network components in centrally funded educational institutions (CFEI) /Central or State Govt. organizations/Large public Enterprise Companies in the last seven years from the due date of bid submission. [The list of Centrally funded Educational Institute is available at Ministry of Education, Government of India Website](#). Bidder must submit copy of relevant Contracts / Work / Purchase orders executed in the last seven years and documentary evidence for successful installation / execution / completion of the above orders along with Names, address and contact details of client(s) shall be uploaded with the bid for verification.

One project of similar nature costing not less than the amount equal to 10 Crores

OR

Two projects of similar nature costing not less than the amount equal 7 Crores each

OR

Three projects of similar nature costing not less than the amount equal to 5 Crores each

‘Similar Projects’ is defined as, Supply, installation and maintenance of IT hardware & System Networking like network switches, wireless solution, LAN cabling, servers, network security devices.

- c. **Financial Criteria:**

1. The minimum Average Annual Turnover of the Bidder must be INR 40 crores as per their audited financial statement during three preceding financial years.

2. Average Annual Turnover: Preceding 3 (Three) financial years mentioned in aforesaid BEC refer to immediate 3 preceding financial years wherever the closing date of the bid is after 30th September of the relevant financial year. In case the tenders having the due date for submission of bid up to 30th September of the relevant financial year and audited financial results of the immediate 3 preceding financial years are not available, the audited financial results of the 3 years immediately prior to that will be considered.

3. **Net Worth**

Net worth of the Bidder shall be Positive as per the immediate preceding financial year statement.

4. **Working Capital**

Working Capital of the bidder must be minimum INR 3 crores as per the immediate preceding last audited financial year statement.

Only documents (Purchase Order, Completion certificate, Execution Certificate etc.) which have been referred/ specified in the bid shall be considered in reply to queries during evaluation of Bids. After submission of bid, only related shortfall documents will be asked for in TQ/CQ and considered for evaluation. For example, if the bidder has submitted a contract without its completion/ performance certificate, the certificate will be asked for and considered. However,

no new reference/ PO/WO/LOA is to be submitted by bidder in response to TQ/CQ so as to qualify and such documents will not be considered by IIM Raipur for evaluation of Bid.

Any shortfall information / documents on the Audited Annual Report / Financial Statement of the Bidder and/or line of credit for working capital issued on or before the final bid due date can only be sought against Commercial queries (CQs). Any information/ documents issued post final bid due date shall not be considered for evaluation.

- d. Bidder should have ISO 9001 and ISO 27001 certification.
- e. Bidder should not be blacklisted in India in the last three years and any blacklisting should not be effective on the date of bid opening. A self-certified undertaking from the authorized signatory to be submitted as per the format.
- f. Power of Attorney (PoA) shall be issued in the name of authorized person signing the bid documents on behalf of the bidder & it is to be submitted in original.

3.1 OEM Criteria for Active Components:

S.No.	Pre-qualification criteria	Compiled (Yes/No)	Remarks
1	Proposed OEM must be present in India for the last 15 years or more.		
2	Similar deployment in India – OEM should have deployed similar campus networking solutions in Centrally funded educational institutions (CFEIs/IIMs)/ Central or State Govt. organizations/Large public Enterprise Companies in last 7 years with minimum 2000 network nodes and minimum 1000 access points successfully deployed in any of these organizations for a minimum of one year. Proof to be submitted in the form of Purchase orders/completion certificate from end customer.		
3	Products proposed should have been released and shipments commenced at least 12 months before date of bid.		
4	OEM should provide an undertaking that the proposed models are latest and spares support for the models offered will be available for a period of 8 years from the date of bid submission. OEM must have at least 15 spare depot centers in India including one in Raipur so that timely replacement can be done for IIM. OEM to submit undertaking confirming the same and providing list of depot Centres on their letterhead		
5	Support during the warranty / AMC period will include back lining with OEM, advance replacement of faulty parts, labor and onsite support to resolve issues reported by IIM within the SLA defined by IIM. Bidder to undertake preventive maintenance visits once every 6 months and do patch updates		

	and updates to the latest version in the switches/wireless controller / access points during these visits.		
6	OEM should have 24*7 TAC (Technical Assistance Centre) support based in India. OEM should provide direct TAC support to IIM as and when required during the warranty period. OEM should confirm in their warranty letter that warranty support part codes considered by bidder includes direct 24/7 TAC support from OEM to IIM Raipur.		
7	OEM should participate via their authorized partners in this bid. MAF to be provided to the authorized partner and OEM should submit an undertaking that they will support IIM Raipur directly or via another partner, if the bidder fails to fulfil their contractual obligations with respect to support during warranty or AMC period.		
8	All active networking components (Network switches, Wireless access points, Wireless controller) should be from the same OEM.		
9	OEM through SI/bidder has to submit "unpriced part coded bill of material" for complete BoQ offered along with technical compliances on OEM letterhead.		

a. OEM Criteria for Passive Components:

S.No	Pre-qualification criteria	Compiled (Yes/No)	Remarks
1	Passive OEM offered must be present in India for at-least 15 years or more.		
2	OEM should have members participating in Telecommunications Industry Association committee with presence in all of the Telecommunication subcommittees of the following: TIA TR-42.1 Subcommittee on Commercial Building Telecommunications Cabling TIA TR-42.5 Infrastructure Terms Subcommittee TIA TR-42.10 Sustainable Information Communications Technology Subcommittee		
3	OEM should be a member of Telecommunications Industry Association (EIA / TIA) Information.		
4	All cables & components offered should be ROHS complied & the same shall be mentioned in their Data Sheet		
5	OEM Should be ISO certified organization		
6	All passive products should be from single OEM & should have 25 years of channel performance and component warranty.		

4 RFP Background

The **Indian Institute of Management Raipur (IIM Raipur)** is a business school and an institution of national importance located in Raipur, Chhattisgarh, India. It is the tenth Indian Institute of Management (IIM) established by the Government of India.

In today's digital age, a reliable and secure Network Infrastructure including Campus wide Wi-Fi network is essential for any establishment.

Campus Wi-Fi typically refers to the wireless internet network provided on a college or university campus. It is an essential service for students, faculty, and staff to access the internet for research, coursework, communication, and other online activities while on campus.

Some key points related to campus Wi-Fi are.

Availability: Campus Wi-Fi is usually available in various locations across the campus, including classrooms, libraries, dormitories, outdoor spaces, and common areas. The goal is to ensure that students and faculty have easy access to the internet wherever they are on campus.

Access Control: To prevent unauthorized access and ensure security, most campus Wi-Fi networks require users to log in with their university-issued credentials (username and password).

Speed and Capacity: Campus Wi-Fi networks need to provide high-speed and high-capacity connections to accommodate the needs of many simultaneous users. This is especially important during peak usage times, such as when multiple students are in a lecture hall or library.

Coverage: Campuses are often large, so Wi-Fi networks must have adequate coverage to reach all areas. This might require a network of access points strategically placed throughout the campus.

Support for Various Devices: Campus Wi-Fi should be compatible with various devices, including laptops, smartphones, tablets, and other internet-connected devices.

Security: Maintaining the security of the network is crucial to protect sensitive data and ensure that only authorized users can access it. This may involve encryption, firewalls, and other security measures.

Guest Access: Many campuses also offer guest Wi-Fi access for visitors or those who are not part of the university community. Guest networks are typically separate from the main network to maintain security.

Bandwidth Management: Sometimes, campus IT departments may need to implement bandwidth management policies to ensure fair usage among all users. This can help prevent network congestion.

4.1 Overview of the Existing Network Setup and Challenges:

Currently at IIM Raipur, around 2300 nos. LAN & Voice points have been distributed to end user using GPON technology in a spread out way. OFC backbone to connect various buildings with server room as well as the passive cabling are not in a reliable state for operational purpose due to overage of cables.

Current network system faces several challenges that hinder its efficiency and effectiveness, prompting the need for a revamp.

- **Scalability Issues:** As the institute continues to grow in terms of student intake, faculty, and administrative staff, the current network infrastructure struggles to keep pace. The existing setup is unable to scale to a level that is required to accommodate the increasing number of users and devices connecting to the network.
- **Poor Performance:** Users experience slow internet speeds, frequent network congestion, and latency issues, especially during peak hours. This compromises productivity and hampers essential academic and administrative activities such as online research, course delivery, and communication.
- **Inadequate Security Measures:** The current setup lacks robust security measures to protect against cyber threats and safeguard sensitive data. This leaves the institute vulnerable to potential breaches, data theft, malware attacks, and other cybersecurity risks, posing a significant concern for the confidentiality, integrity, and availability of information.
- **Unreliable Connectivity:** Downtime and frequent network outages disrupt academic activities, administrative operations, and communication channels. Unreliable connectivity leads to frustration among users and negatively impacts the institute's reputation.
- **Insufficient Bandwidth:** The available bandwidth may not meet the increasing demands for high-speed internet access, multimedia content streaming, video conferencing, and other bandwidth-intensive applications. This results in network congestion, degraded performance, and a poor user experience.
- **Limited Wireless Coverage:** The wireless network coverage across the campus may be inadequate, resulting in dead zones or areas with weak signals. This restricts mobility and access to online resources, particularly in areas such as classrooms, libraries, and common areas.
- **Complex Network Management:** The lack of centralized network management tools and resources complicates network monitoring, configuration, and troubleshooting processes. Network administrators face challenges in identifying and resolving issues promptly, leading to prolonged downtime and service disruptions.

In conclusion, the existing network setup at IIM Raipur suffers from various shortcomings that hinder its functionality, reliability, and security and hence requires a complete revamp of the Network Infrastructure including the passive and fibre cabling infrastructure

The RFP being floated is aimed at addressing these challenges through a comprehensive revamp of the network infrastructure and to ensure seamless connectivity, optimal performance, and enhanced cyber security posture for the institute.

4.2 Proposed Solution to overcome existing challenges:

a. Achieving high-performance connectivity with a network bandwidth of 10 Gbps (10 Gigabits per second) involves several key considerations and components, i.e.

- **Hardware Infrastructure:** Utilize network switches, routers, and network interface cards (NICs) that support 10 Gigabit Ethernet (10GbE) interfaces. These devices should have sufficient processing power and port density to handle the increased bandwidth.
- **Fiber Optic Cabling:** Deploy high-quality, low-latency fibre optic cables capable of supporting 10GbE speeds. Single-mode fiber (SMF)
- **Network Topology:** Design the network topology to minimize latency and optimize throughput. Consider factors such as link aggregation (using techniques like LACP) for increased bandwidth and redundancy, as well as proper VLAN segmentation for traffic isolation and security.
- **Quality of Service (QoS):** Implement QoS policies to prioritize critical traffic types and ensure consistent performance for latency-sensitive applications such as VoIP or video conferencing.
- Eliminating single points of failure in the core and wireless controller network is crucial for ensuring high availability and reliability of the network infrastructure. Some of the design elements incorporated to achieve this include :

Redundant Hardware: Implement redundancy at critical points in the network by deploying redundant core switches, routers, and wireless controllers. This involves using technologies like Virtual Router Redundancy Protocol (VRRP) or Hot Standby Router Protocol (HSRP) for routers, and Virtual Switching System (VSS) or Virtual Port Channel (vPC) for switches.

- **Redundant Power Supplies and Power Sources:** Equip network devices with dual power supplies and connect them to redundant power sources (such as uninterruptible power supplies or backup generators) to ensure continuous operation even in case of power failures.
- **Redundant Links and Paths:** Configure redundant links between core switches, routers, and wireless controllers to create alternate paths for traffic in case of link failures. Use protocols like Rapid Spanning Tree Protocol (RSTP) or Multi-Chassis Link Aggregation (MLAG) to manage redundant links efficiently.
- **High Availability Features:** Enable high availability features on network devices, such as stateful failover and fast convergence mechanisms, to minimize downtime in the event of component or link failures. This includes technologies like Bidirectional Forwarding Detection (BFD) for fast link failure detection.

b. Deploying a wireless network with a centralized controller-based architecture using IETF CAPWAP-based operation involves several steps and considerations. CAPWAP (Control and Provisioning of Wireless Access Points) is a standard protocol defined by the IETF (Internet Engineering Task Force) for the control and provisioning of wireless access points (APs) by a centralized wireless LAN (WLAN) controller.

- **Network Planning and Design:**

Conducted a site survey to assess the wireless coverage requirements and identify optimal AP placement locations. Determined the number of APs needed to provide adequate coverage and capacity for your wireless network. Design the network topology, including the placement of WLAN controllers, to ensure optimal coverage and performance.

- **Selecting WLAN Controllers:**

Choose WLAN controllers that support CAPWAP-based operation and provide the scalability, performance, and feature set required for your deployment. Consider factors such as maximum supported APs, throughput, redundancy options, and integration with other network management systems.

- **Selecting Access Points:**

Select wireless APs that are compatible with the chosen WLAN controllers and support CAPWAP for centralized management and control. Consider factors such as supported wireless standards (e.g., 802.11ac, 802.11ax), antenna configuration, and deployment options (indoor, outdoor).

- **Network Configuration:**

Configure the WLAN controllers with network settings, VLAN configurations, security policies, and other parameters as per the network design. Configure CAPWAP settings on both the WLAN controllers and APs to establish communication and control channels between them.

- **AP Deployment:**

Install and mount the APs in their designated locations according to the site survey and design specifications. Connect the APs to the network infrastructure, ensuring proper cabling and power supply. Establishment of a secure network infrastructure.

c. Establishment of a redundant cluster with dual wireless controllers:

- Implement robust security measures such as WPA2/WPA3 encryption, 802.1X authentication, and intrusion detection/prevention systems to secure the wireless network.
- Configure firewall rules and access control lists (ACLs) on the WLAN controllers to control traffic between wireless and wired networks.

d. Scalability achieved through horizontal expansion of the network to support ever-evolving applications and services.

e. Implementation of redundant configuration of Wireless IPS to collaborate with WLAN controllers, ensuring secured Wi-Fi service throughout the campus.

4.3 Requirements at IIM Raipur Site

- **Overhaul the existing network backbone to augment/upgrade:** This includes a comprehensive review and enhancement of the core network infrastructure to improve its capacity, reliability, and performance. It also involves upgrading hardware components such as switches, routers, and cables, as well as optimizing network configurations.
- **Implement a high-performance network backbone with 10G connectivity:** This entails installing a robust backbone network capable of handling high data volumes with 10 Gigabit per second (Gbps) connectivity speeds. It involves deploying switches, routers, and cables that support 10G Ethernet standards.
- **Deploy a smart network infrastructure capable of sustaining triple play services:** Triple play services typically include voice, video, and data services delivered over a single network infrastructure. Deploying a smart network infrastructure involves implementing technologies that can efficiently handle these diverse services without compromising performance.
- **Provide a mix of wired and wireless connectivity to new locations as per suitability and convenience:** This suggests offering both wired and wireless connectivity options to accommodate various user needs and preferences. It involves deploying Ethernet ports for wired connections and Wi-Fi access points for wireless connectivity in different areas of the campus.
- **Ensure wireless access for over 3000 users 24x7x365:** There is a need to provide reliable and uninterrupted wireless access to accommodate a large number of users throughout the year, including weekends and holidays. It requires deploying sufficient Wi-Fi infrastructure and implementing measures to manage network congestion and ensure quality of service.
- **Seamlessly integrate all network components:** This involves ensuring compatibility and smooth operation among different network components such as switches, routers, access points, and management systems. It requires proper configuration, testing, and monitoring to achieve seamless integration.
- **Optimize the utilization of existing infrastructure wherever possible:** This involves maximizing the efficiency and effectiveness of existing network infrastructure to minimize costs and resources. It involves upgrading existing equipment, optimizing network configurations, and implementing resource management strategies.
- **Implement an Enterprise Network Management System for monitoring and managing the entire campus network:** This involves deploying a comprehensive network management system capable of monitoring, configuring, and managing all network devices and services across the campus. It includes features such as performance monitoring, configuration management, fault detection, and security management.
- **Conduct training for preliminary maintenance and monitoring of the network system:** This entails providing training sessions or workshops to relevant personnel responsible for maintaining and monitoring the campus network. The training should cover topics such as basic troubleshooting, configuration management, and best practices for network maintenance.
- **Perform a test run to ensure the proper operation of the entire network:** Before fully deploying the network infrastructure, it's crucial to conduct thorough testing to verify its performance, reliability, and security. This involves simulating various usage scenarios, conducting stress tests, and identifying and resolving any issues or vulnerabilities before production deployment.

NETWORK CONNECTIVITY IN RING TOPOLOGY

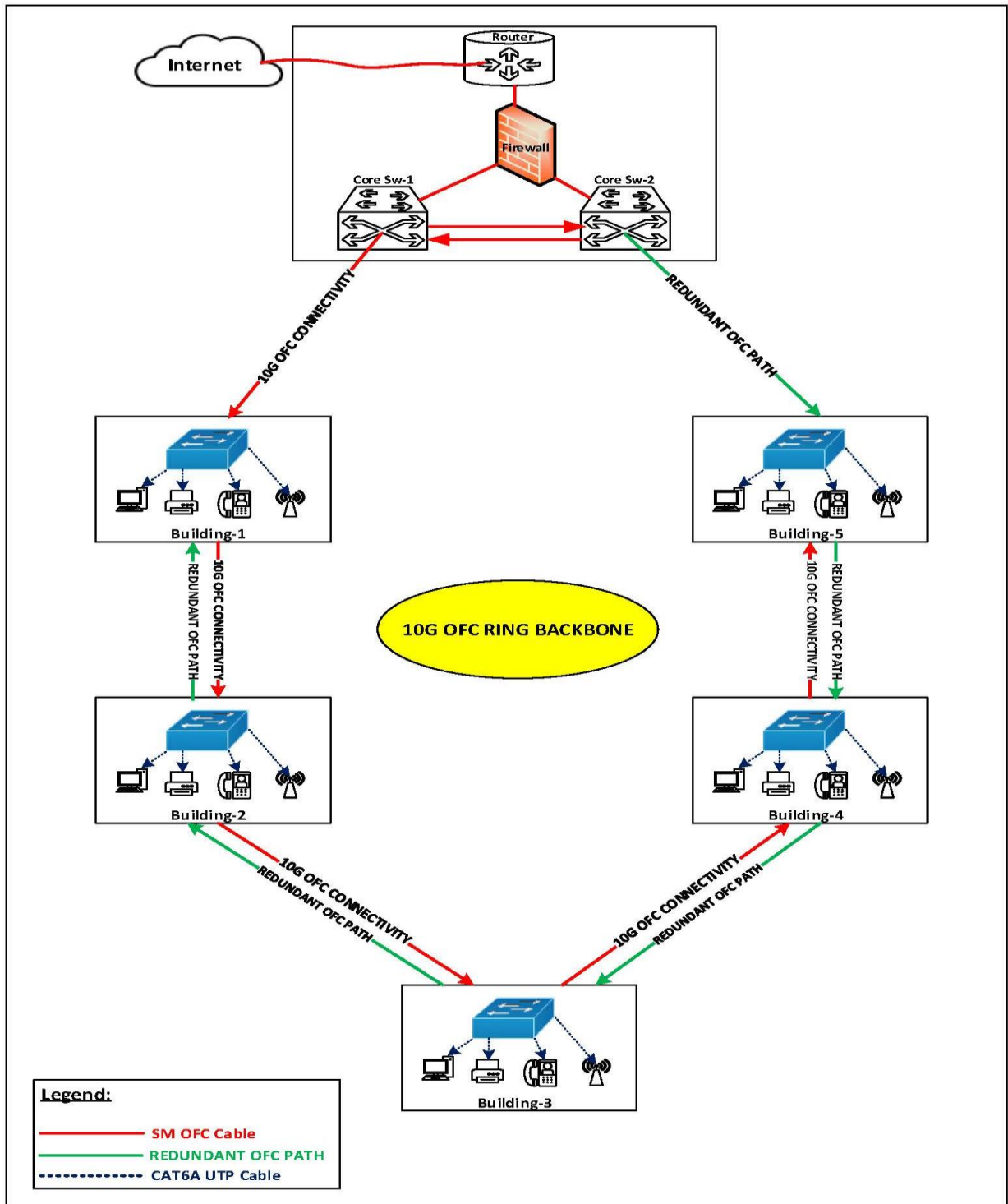

5 Scope of Work

The scope of the RFP covers implementation (including any design modifications based on site requirements) of the proposed augmentation of campus wide Network Infrastructure including the Wireless network (Wi-Fi) with the necessary passive and active work. The Network Infrastructure so deployed should be capable to support partial as well as situation of complete outage of any one site as well as requirement of additional operational facilities and enhancement of overall throughput. The design is supposed to take care of the following objectives:

- Establishment of a Server rack setup in Academic building for core devices
- Connecting the required location/buildings containing end-points/nodes to the network backbone in such a fashion so as to avoid single point of failure in the network and increase path redundancy in a cost effective manner.
- Providing a secured wireless networking solution at places where traditional wired network connectivity is difficult to implement and support.
- Utilize Managed Networking equipment to ensure segmentation of the network for better management and performance.
- Ensure Active Network components are scalable for future expansion and better return on investment.
- Usage of optimal quantity of passive components.
- Increasing network throughput and availability by designing a resilient and load-sharing architecture with multiple Layer-3 network routes to overcome device or link failures.
- Implement quality of service to ensure optimum network resource usage, eliminate network congestion and facilitate smooth flow of data and surveillance video traffic across the network.
- Installation, customization, and commissioning of the Network Components proposed as well as the solution resulting thereof.
- Maintenance of the same for a period of seven years for passive infrastructure and three years for active infrastructure in **a comprehensive manner post warranty period of one and five years respectively**. Total eight years from the date of acceptance.
- Supporting and coordinating security audit certification as and when needed as per GOI guidelines. The SI will be responsible for getting the network audited Government of India approved security auditors. The security audit will be done during the contract period by approved auditors. That is, the security audit support is under the scope of work and the SI is responsible for getting the audit certification as per GOI norms. The Security Audit charges to the Empaneled auditor will be paid by IIM Raipur. The SI will also be responsible for addressing and resolving any identified security vulnerabilities uncovered during the security audit.

1. Wired Campus

Installation of RJ45 data outlet points: Strategically place RJ45 data outlet points throughout the campus, including rooms, common areas, and other designated locations.

Connectivity setup: Connect data outlet points to Rack Panels/Computer hubs using 4 pair CAT-6A wiring in raceways or conduits, ensuring efficient connectivity.

Power supply provision: Providing UPS power supply to Network Racks, Servers, and Computers wherever necessary to ensure uninterrupted operation will be in IIM Raipur scope.

Cable length management: Ensure that the maximum length of CAT 6a cable from end-user points to Hub or Edge switches does not exceed 70 meters. Utilize Fibre Optic Cable for longer distances beyond 70 meters.

Redundant connectivity: Establish redundant connectivity paths to the core switch from each building to ensure seamless connectivity.

Server connectivity: Connect servers to the core switch via Optical Fibre cable for high-speed and reliable connections.

Infrastructure setup: Install necessary infrastructure components including Rack Panels, Network switches, patch cords, power supply units, cooling fans, Wire managers, LIUs, Trans-receivers, Fiber patch cord, etc., in individual buildings/Blocks/floors.

Manhole provision: Construct brick masonry manholes with covers at suitable lengths to facilitate easy wire/cable pulling and maintenance.

Integration with existing systems: Ensure seamless integration of the wired infrastructure with existing systems and networks on the campus.

Compliance and standards: Adhere to industry standards and best practices for wired network infrastructure deployment to ensure reliability, scalability, and security.

The scope of work for the wired campus aims to provide a robust and reliable network infrastructure that supports the connectivity needs of students, faculty, and staff across the campus premises.

Wireless Network

- Indoor wireless network has to be based on latest IEEE 802.11ax standards and should support multiuser MIMO (MU-MIMO).
- All Access points should be managed by centralized wireless controller placed in campus datacentre. This wireless controller should be configured in high availability (HA) preferably in Active/Passive configuration to avoid any downtime.
- Indoor Access points shall be powered on via POE/UPOE access switches supporting gigabit standards. The minimum number of Indoor access points estimated are 400 Nos. for proper coverage in the entire campus. However, bidders keen to participate in this bid are free to do the SITE survey on their own without any financial implication on IIM Raipur & propose their estimation on APs count. Bidders have to ensure 100% coverage & no dark spots.
- Network solution to manage both switching and wireless network devices spread across the campus network.
- Going forward may add additional services like IOT devices etc. Network must be secure enough to add any new services as & when required.
- New Wi-Fi setup will be used to provide data and internet access to students, faculties, Staff, various equipment securely & residential users with different levels of access. This may increase over period of time and may require different set of security policies to access network. Selected SI shall have to define the security policies accordingly from time to time.
Bidders, who have the capability to provide a TOTAL TURNKEY solution which covers design/development of a suitable architecture/layout of the proposed networking system, pre-dispatch inspection / testing, packing and forwarding, transportation, insurance and carrying out further activities at sites viz. unloading, storage, (space to be provided by the IIM Raipur) further handling, erection, testing and commissioning including successful completion of acceptance tests and any other services specified.

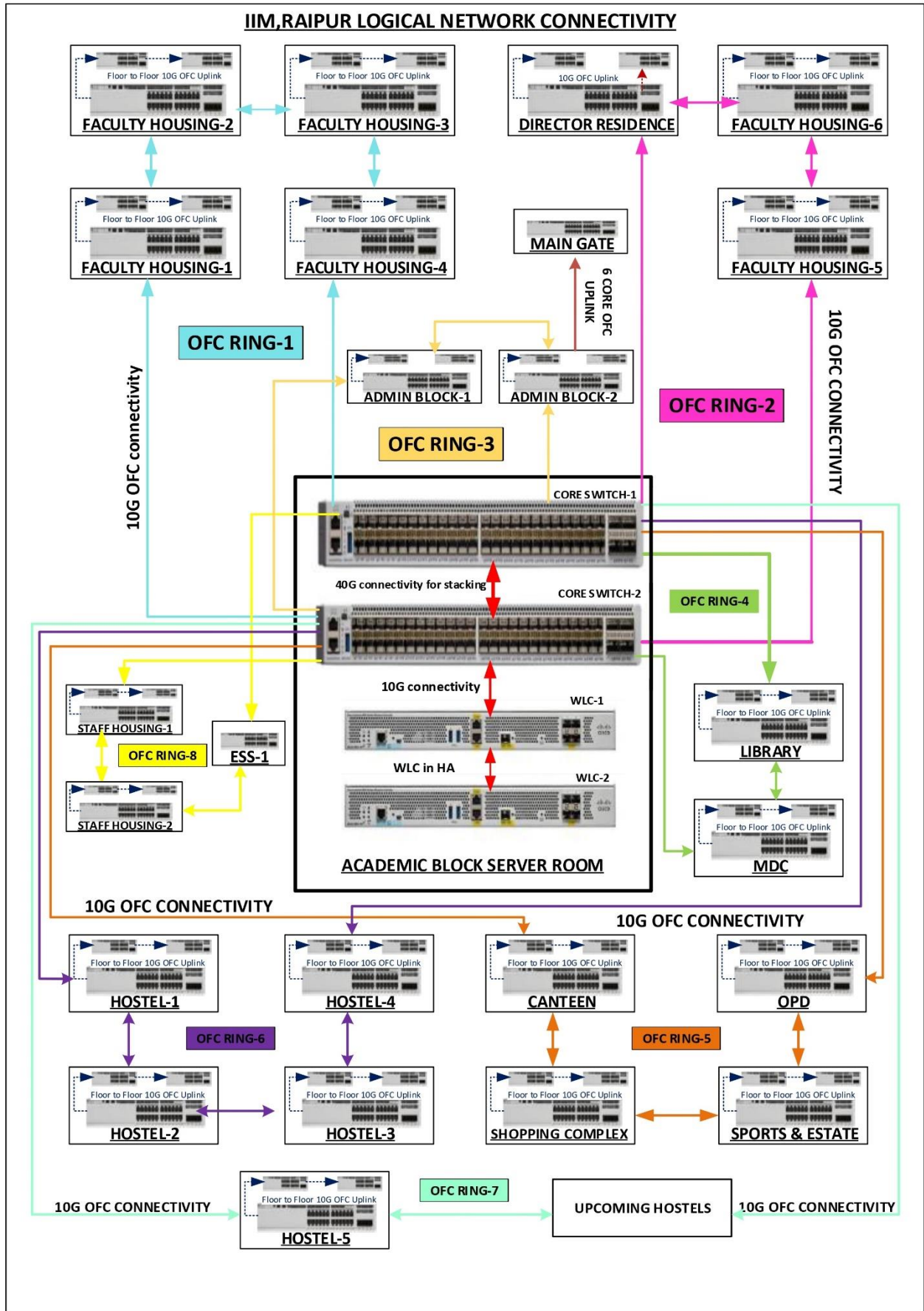

HOSTEL BLOCKS LOGICAL CONNECTIVITY WITH 10G OFC REDUNDANT PATH

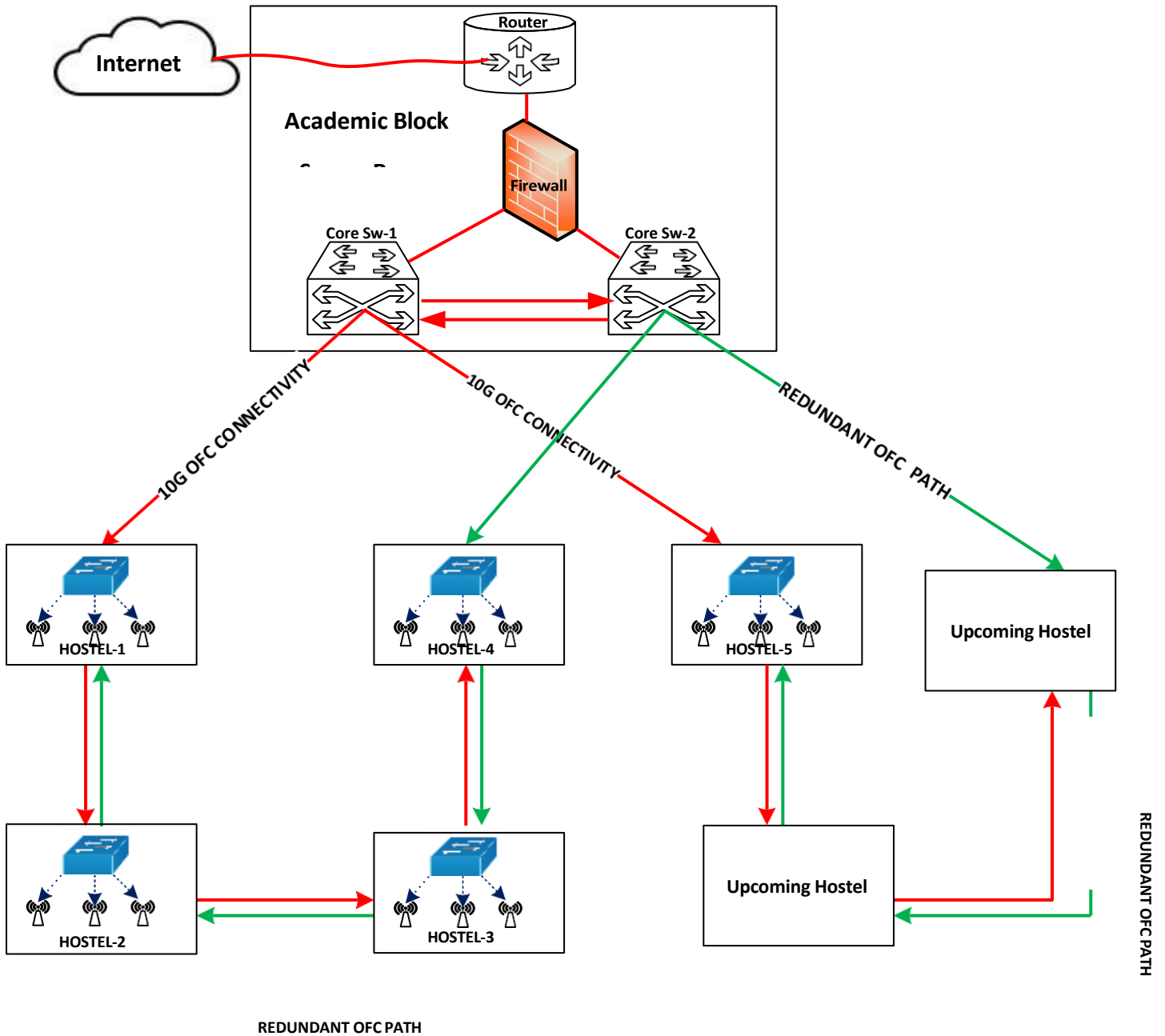

Legend:

- SM OFC Cable
- REDUNDANT OFC PATH
- CAT6A UTP Cable

Proposed OFC cabling backbone with Logical Layout

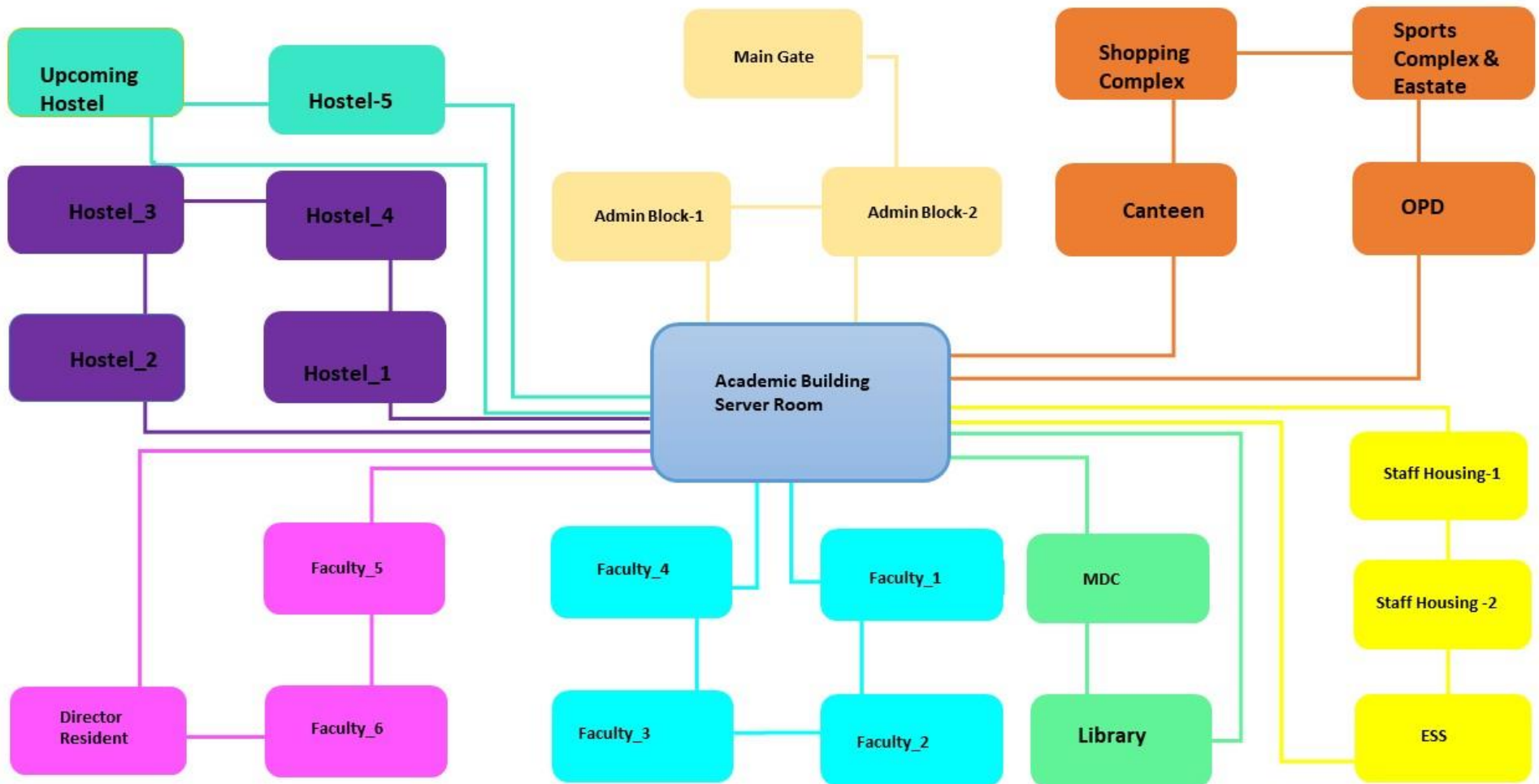

5.1 Proposed BOQ of Active Components (for bid evaluation purpose only):

Active Components			
1	Wi-Fi 6 Access Points 4x4 on 2.4 & 5 GHz – Type I	Nos.	275
2	Wi-Fi 6 Access Points 4x4 on 2.4 & 5 GHz – Type II	Nos.	140
3	WiFi6 Access Points 4x4 on 2.4GHz and 8x8 on 5GHz – Type III	Nos.	1
4	Wireless LAN Controller (WLC) in HA	Nos.	2
5	Core Switch 48-port in Stacking with redundant power supply Including 100GBASE-LR4 QSFP+ transceiver module for SMF	Nos.	2
6	12 ports Layer-2 full PoE+ with 2x 10G SFP+ fixed uplinks	Nos.	8
7	12 ports Layer-2 Non Poe (12-port 1G, 2x10G SFP+)	Nos.	17
8	24 port Layer-2 PoE+ Access Switch with 24 X 10/100/1000 Mbps PoE+ ports & 4 X 1/10G SFP+ ports	Nos.	28
9	24 ports Layer 2 Non PoE (24-port 1G, 4x 1/10G fixed uplinks)	Nos.	20
10	48 ports Layer 2 Non PoE (24-port 1G, 4x 1/10G fixed uplinks)	Nos.	5
11	48 ports Layer 2 PoE+ (48-port 1G, 4x 1/10G fixed uplinks)	Nos.	8
12	24 Port Layer 2 Multigigabit Switch (8 port mGig ports up to 10G, 16 ports up to 1G)	Nos.	9
13	24 port mGig UPOE+ Switch, 24x 10G Multigigabit (10G/5G/2.5G/1G/100M)	Nos.	2
14	48 port 5Gbps Multigigabit UPOE Switch (5G/2.5G/1G/100M)	Nos.	5
15	Small form-factor pluggable transceiver - SM (SFP+)	Nos.	200
16	NMS with hardware	Nos.	1
17	Hardware with latest Windows Server edition for Domain Controller, DHCP, hypervisor etc.	Lot	1

5.2 Proposed BOQ of Passive Components (for bid evaluation purpose only):

S. No.	DESCRIPTION	UOM	QUANTITY
1	CAT6A UTP Cable Indoor (Box of 305 Meters)	Box	353
2	CAT 6A UTP 12 Port Patch Panel Loaded	Nos.	27
3	CAT 6A UTP 24 Port Patch Panel Loaded	Nos.	94
4	CAT 6A UTP I/O with Face Plate & SMB	Nos.	1955
5	CAT6A UTP Patch Cord-2 Meter	Nos.	1955
6	CAT6A UTP Patch Cord-1 Meter	Nos.	1955
7	24-Core Fibre Optic Outdoor Armoured cable	Mtrs.	14000
8	06-Core Fibre Optic Outdoor Armoured cable	Mtrs.	500
9	06-Core Fibre Optic Indoor Armoured cable	Mtrs.	3000
10	12 port LIU,1U Rack mount enclosure LC-LC Fully loaded	Nos.	69
11	24 port LIU,1U Rack mount enclosure LC-LC Fully loaded	Nos.	1
12	48 port LIU,1U Rack mount enclosure LC-LC Fully loaded	Nos.	10
13	Optical Fibre duplex Patch Cord, SM, LC-LC, Length 3 m	Nos.	210
14	12U network Rack, Wall Mount	Nos.	56
15	15U network Rack, Wall Mount	Nos.	14
16	42U Network Rack, Floor Mount	Nos.	1
17	Cable Manager 1U	Nos.	102
18	HDPE Duct Pipe 33/40MM	Mtrs.	9000
19	HDPE Duct Pipe 25MM	Mtrs.	1500
20	G.I. Pipe 50MM with all accessories	Mtrs.	500
21	25mm PVC Pipe	Mtrs.	8000
22	40mm PVC Pipe	Mtrs.	4000
23	25mm PVC Casing	Mtrs.	4000
24	40 mm PVC Casing	Mtrs.	2000
25	32mm PVC Flexible Pipe	Mtrs.	500
26	32mm Armoured Flexible Pipe	Mtrs.	500
27	OFC Route Marker	Nos.	250
28	Outdoor OFC cable enclosure jointer	Nos.	15
29	Miscellaneous items and accessories	Lot	1
30	Technical manpower charges for One year (One L3 – Specialist and One L2 – network& Monitoring Resource and One Server Engineer)	Nos.	3
31	Comprehensive Annual Maintenance support for Nodes....	years	7

In addition to the above, the selected bidder will depute three (03) technical engineers at IIM Raipur for a period of one year. The engineers shall have adequate experience in independently managing same/similar projects of this kind.

1. Engineer | L3 - Specialist - 05 years of Experience
2. Server Engineer - 03 years of Experience
3. Engineer | L2 - Network & Monitoring - 02 Years of Experience

THE ABOVE BOQ IS INDICATIVE ONLY. ALL BIDDERS SHOULD CONDUCT A DETAILED SITE SURVEY OF THE CAMPUS AND UNDERSTAND THE REQUIREMENTS COMPLETELY BEFORE SUBMITTING THE TENDER. ANY CHANGE IN REQUIREMENTS AT SITE TO ENSURE DELIVERY OF THE REQUIRED CAPABILITIES DEFINED ABOVE NEED TO BE CONSIDERED AND BIDDER SHOULD QUOTE ACCORDINGLY.

5.3 Call Flow and Escalation Matrix - Operations & Maintenance

Operation and Maintenance Support goes through the following phases:

- a) Support Call Logging
- b) Support Call Resolution
- c) Support Call Closure

The subsequent paragraphs describe the various activities that take place in each of the above phases, the necessary reports and returns that need to be generated and the quality processes that need to be adhered to.

5.4 Training

3 days training shall be imparted by experienced & certified person from the selected SI with sufficient experience. A considerable practical/ hands-on training shall be included apart from imparting theoretical training.

The proposed schedule for the same is as below

Schedule for Training :

Sr.No.	Topics for Training
1	Basics of Data Networking & logical Connectivity
2	Layer 2 & Layer 3 Switches, Wireless Controller & Access Point
3	Network Fault identification, Troubleshooting, Administration, Policies formulation and management, Network Monitoring, report generation
4	Network Management Systems installation and handling, usage.

6. TECHNICAL SPECIFICATIONS

6.1 ACTIVE COMPONENTS

6.1.1 Wireless Controller

S. No	Technical Specifications	Compliance
1	AP should be able to tunnel traffic to remote location to WLC/tunnel aggregator device using protocols like VxLAN/EoGRE/L2TP/Capwap/GRE	
2	Proposed WLC should be an on premise HW appliance based solution. No VM based solutions are accepted.	
3	Support for new Wi-Fi 6 (802.11ax), WPA3 and Enhanced Open and existing standards	
4	WLC should have capability to host 2000 APs from day 1.	
5	WLC should support 30K or more clients	
6	WLC/ WLAN Tunnel aggregator devices should have 4 nos. of 1/10G SFP+ to connect to LAN	
7	Should support multiple redundancy models like 1+1. On Premise WLC Must support 1+1 or N+1 redundancy	
8	WLC Must support an ability to dynamically adjust channel, power settings and airtime, based on the RF environment. Radio coverage algorithm must allow adjacent WAPs to operate on different channels, in order to maximize available bandwidth and avoid interference.	
9	Wireless Controller should support Access Control based on Identity/Role/Device/Time or Application.	
10	WLC should have 4K VLANs	
11	should supports IPSec/SSL encryption standards	
12	Should support coverage hole detection and correction that can be adjusted on a per WLAN basis.	
13	Should support RF Management with 20, 40, 80 & 160 MHz channels	
14	Should support Access Control Lists (ACLs).	
15	Should support built-in /URL redirection for web authentication	
16	Should be able to set a maximum per-user bandwidth limit on a per-SSID basis.	
17	Should provide Mesh capability for Mesh supported AP	
18	Must support client roaming as per IEEE standard 802.11r or WLC/APs across layer3 routed boundaries	
19	Should support spectrum analysis and be able to classify different types of interference.	
20	Should provide multiple real-time charts/log showing interferers per access point, on a per- radio, per-channel basis.	
21	System should provide real-time troubleshooting and visualization. Any specialized hardware and software required for the same should be provided by the vendor.	
22	WLC should support Application Visibility and Control (AVC).	
23	Support for configuring media streams with different priority to identify specific video streams for preferential QoS treatment.	
24	To deliver optimal bandwidth usage, reliable multicast must use a single session	

	between AP and Wireless Controller.	
25	Should support IPv4 & IPv6.	
26	For smooth, seamless and easy manageability, operation, interoperability and maintenance, the bidder should offer/quote WLC & WAPs of the same make (OEM).	
27	Solution should support application visibility and control (applications like Social Media, Video Streaming, Video Conferencing apps, etc.)	
28	The solution should detect and automatically prevent all types of Rogue (unauthorized APs connected to the network) APs.	
29	WLC should support complete WIPS/WIDS support, via integrated or through external appliance	
30	The solution to support automatic packet capture in the event of a client failure or anomalous events.	
31	The WLAN solution should provide an easy GUI view dashboard to use all the settings, configuration, logs, topology view, etc.,	
32	The solution should highlight client connection failures during association, authentication and network entry.	
33	The Solution shall support Hitless/rolling and support AP upgrade feature.	
34	The solution must be able to detect and automatically prevent any ad hoc network/ all Wi-Fi enabled devices such as smartphones bridging / ICS when connected to the network	
35	The solution must support WPA3 - enterprise 192 bit encryption through WLC, if not available on APs.	

6.1.2 WiFi-6 Indoor Access Points Type I

S. No.	Wi-Fi 6 Access Points 4x4 on 2.4 & 5 GHz Technical Specification	Compliance
1	Access Point shall support 4x4 MIMO on both radio interfaces and MU-MIMO technology	
2	Access Point shall be able to support Multigigabit Ethernet, support up to 2.5 Gbps PHY speed using single Cat5e or above(Cat6, Cat6A) cable	
3	Access Point shall be able to powered up using PoE 802.11af provides up to 15.4 watts of power per port	
4	Access Point shall support hardware driven beamforming	
5	Access Point should have Bluetooth5 radio to support use cases of location, asset tracking and analytics.	
6	Access Point should have 1x 100, 1000, 2500 Multigigabit Ethernet (RJ-45) – IEEE 802.3bz	
7	Access Point should have USB port for future requirement.	
8	Must have atleast 3 dBi Antenna gain on each radios	
9	Must Support data rate upto 5Gbps.	
10	Must support minimum of 23dbm of transmit power in both 2.4Ghz and 5Ghz radios. Should follow the local regulatory Norms.	
11	Must support AP enforced load-balance between 2.4Ghz and 5Ghz band.	
12	Must incorporate radio resource management for power, channel and performance optimization	
13	Must have -98 dB or better Receiver Sensitivity.	
14	Must support Proactive Key Caching and/or other methods for Fast Secure Roaming.	
15	Must support Management Frame Protection.	
16	Should support locally-significant certificates on the APs using a Public Key Infrastructure (PKI).	
17	Must support the ability to serve clients and monitor the RF environment concurrently.	
18	Same model AP that serves clients must be able to be dedicated to monitoring the RF environment.	
19	Must be plenum-rated (UL2043).	
20	Must support 16 WLANs per AP for SSID deployment flexibility.	
21	Access Point Must continue serving clients when link to controller is down. It should also have option to authenticate user through Radius server directly from Access Point during link unavailability to controller.	
22	Must support telnet and/or SSH login to APs directly for troubleshooting flexibility.	
23	802.11e and WMM	
24	Must support QoS and Video Call Admission Control capabilities.	
25	Access point should be Wi-Fi 6 certified	

6.1.3 WiFi-6 Indoor Access Points Type II

S. No.	Wi-Fi 6 Access Points 4x4 on 2.4 & 5 GHz Technical Specification	Compliance
1	Access Point shall support 4x4 MIMO on both radio interfaces and MU-MIMO technology	
2	Access Point shall be able to support Multigigabit Ethernet, support up to 2.5 Gbps PHY speed using single Cat5e or above(Cat6, Cat6a, Cat7) cable	
3	Access Point shall be able to support full features at 802.11at can deliver up to 30 watts of power per port	
4	Access Point shall be able to powered up using PoE 802.11af provides up to 15.4 watts of power per port	
5	Access Point shall support Dual 5GHz radios	
6	Access Point shall have dedicated radio/chipset for spectrum monitoring capabilities, WIPS and off channel RRM without compromising and using the client serving radios.	
7	Access Point shall support hardware driven beamforming	
8	Access Point shall be IoT ready (Zigbee) and container support for IOT applications.	
9	Access Point should have Bluetooth5 radio to support use cases of location, asset tracking and analytics.	
10	Access Point should have 1x 100, 1000, 2500 Multigigabit Ethernet (RJ-45) – IEEE 802.3bz	
11	Access Point should have USB port for future requirement.	
12	Must have atleast 4 dBi Antenna gain on each radios	
13	Must Support data rate upto 5Gbps.	
14	Must support minimum of 23dbm of transmit power in both 2.4Ghz and 5Ghz radios. Should follow the local regulatory Norms.	
15	Must support AP enforced load-balance between 2.4Ghz and 5Ghz band.	
16	Must incorporate radio resource management for power, channel and performance optimization	
17	Must have -97 dB or better Receiver Sensitivity.	
18	Must support Proactive Key Caching and/or other methods for Fast Secure Roaming.	
19	Must support Management Frame Protection.	
20	Should support locally-significant certificates on the APs using a Public Key Infrastructure (PKI).	
22	Must support the ability to serve clients and monitor the RF environment concurrently.	
23	Same model AP that serves clients must be able to be dedicated to monitoring the RF environment.	
24	Must be plenum-rated (UL2043).	
25	Must support 16 WLANs per AP for SSID deployment flexibility.	
26	Access Point Must continue serving clients when link to controller is down. It should also have option to authenticate user through Radius server directly from Access Point during link unavailability to controller.	
27	Must support telnet and/or SSH login to APs directly for troubleshooting flexibility.	
28	802.11e and WMM	
29	Must support QoS and Video Call Admission Control capabilities.	

30	Access point should be Wi-Fi 6 certified	
----	--	--

6.1.4 WiFi-6 Indoor Access Points Type III

S. No	WiFi6 AP 4x4 on 2.4GHz and 8x8 on 5GHz - Technical Specifications	Compiled (Yes/No)
1	Access Point shall support 4x4 on 2.4GHz and 8x8 on 5Ghz	
2	Access Point shall be able to powered up using PoE/PoE+/UPoE (.af/.at/.bt)	
3	Access Point shall support assurance, packet capture, RF sensing capabilities	
5	Access Point shall support encrypted traffic visibility	
4	Access Point shall support application visibility and control	
6	Access Point should have BLE/Zigbee radio to support use cases of location, asset tracking and analytics, from Day1	
7	Access Point shall ship with metal/fiber-based mounting bracket for durability and reliability	
8	Access Point shall be able to leverage current Access Point mount kit /cable conduit	
9	Access Point shall provide console based connectivity that uses standard interfaces such as RJ45/serial USB connection/special SSID for initial config and during disconnected network situations. If serial USB connection is supported by the AP model (10nos of min 3ft serial USB cable to be provided at no extra cost).	
10	Access Point should have 1x 1Gbps, 2.5Gbps, 5Gbps multigigabit Ethernet (RJ45).	
11	Access Point should have a USB port for future requirements.	
12	Must Support min. PHY data rate upto 5 Gbps.	
13	Must support a minimum of 23dBm of transmit power in both 2.4Ghz and 5Ghz radios and should follow the local regulatory Norms.	
14	Must support AP enforced load-balance between 2.4Ghz and 5Ghz band.	
15	Must incorporate radio resource management for power, channel and performance optimization	
16	Must have -97 dB or better Receiver Sensitivity.	
17	Must support Proactive Key Caching and/or other methods for Fast Secure Roaming.	
18	Must support Management Frame Protection.	
19	Must support the ability to serve clients and monitor the RF environment concurrently.	
20	Same model AP that serves clients must be able to be dedicated to monitoring the RF environment.	
21	Must be plenum-rated (UL2043).	
22	Access Point must continue serving clients when the internet link to the controller is down. It should also have the option to authenticate users through the Radius server directly from Access Point during link unavailability to the controller in the same LAN segment.	
22	The solution should have high availability of controllers to avoid the single point of failure. In case both controllers fail, APs should have the capability to serve the clients by converting them to FAT/IAP/Bridge mode automatically or with manual configuration changes.	
23	Must support telnet and/or SSH login to APs directly for troubleshooting flexibility.	
24	Must support 802.11e and WMM	
25	Must support QoS and Video Call Admission Control capabilities.	
26	Access point should be wifi 6 certified.	

27	Must support downlink and uplink OFDMA	
28	Must support TWT & BSS coloring	
29	Must support WPA3 - enterprise 192 bit encryption	
30	Peak integrated antenna gain on each radio with min. 4dBi on 4x4 and min. 5dBi on 8x8	

6.1.5 48-Ports Core Switch

S. No	Technical Specifications	Compliance
1	General Features :	
a	Switch should have: 48 x 1/10/25G ports	
b	Switch should have minimum 4x40/100G ports, for creating the HA (within the rack) using stacking/virtual stacking. SM Transceivers for 40G uplinks to be provided, cables/transceivers for stacking for a minimum of two Core switches within each rack to be included with no additional cost in Day1.	
c	Switch shall be 1U and rack mountable in standard 19" rack.	
d	Switch shall have min. 16 GB RAM.	
e	Switch shall have min. 16 flash.	
f	Switch shall have a hot swappable 1:1 redundant internal power supply and redundant fan.	
g	Switch shall support VSS or equivalent features allowing links that are physically connected to two different switches to appear as a single port channel with inter-switch bandwidth of min. 400Gbps	
h	Shall support In Service Software Upgrade (ISSU) or equivalent hitless failover to provide an upgrade of the entire platform or an individual task/process without impacting hardware forwarding.	
i	Switch shall have hot swappable 1:1 redundant internal power supply and redundant fan, on day1	
2	Performance :	
a	Switching system shall have a minimum 2 Tbps of switching fabric and minimum 1Bpps of forwarding rate.	
b	Switching system shall have a minimum 50K MAC Addresses and 4K VLANs.	
c	Switch should support minimum 5K ACLs, 5K Multicast and 30K IPv4, 15K IPv6 Routes.	
d	Switch shall support application visibility and traffic monitoring with minimum 50 K netflow/jflow entries, or with minimum sampling rate of 4096 in case of sflow.	
e	Min. Packet buffer : 30 MB	
f	The device should be IPv6 ready support or logo certified from day one	
3	Functionality :	
a	Should support IEEE Standards of Ethernet: IEEE 802.1D, 802.1s, 802.1w, 802.1x, 802.3ad, 802.1ae (256-bit and 128-bit AES)/VXLAN overlay, 802.3x, 802.1p, 802.1Q, 1588v2/NTP/SNTP	
b	Switch should support routing protocols like BGPv4, OSPF(v2, v3)/ ISISv4, RIP, Static, EVPN, PIM, SSM, BFD, VRF aware BFD, IEEE 802.1ae/VXLAN overlay from day 1 on the same hardware	

c	Shall have 802.1p class of service, marking, classification, policing and shaping. Should support strict priority queuing.	
d	Switch should support API Driven configuration and support Netconf and Restconf using YANG data model. It should support automation tool like python	
e	Switch should support port security/DHCP snooping/first hop security/Spanning tree root guard or equivalent.	
f	IPv6 support in hardware, providing wire rate forwarding for IPv6 network	
g	Should support 802.1x authentication and accounting, IPv4 and IPv6 ACLs and Dynamic VLAN assignment.	
h	Eight egress queues per port for different types.	
i	During system boots or OS upgrades, the system's software should be checked for integrity.	
j	Switch should support management features like SSHv2, SNMPv2c, SNMPv3, NTP, RADIUS and TACACS+, SSL/SSH, SFTP	
k	Switch OS should support programmability through REST APIs and Python scripting or equivalent	
4	Security	
a	Switch should support for sending logs to multiple centralised syslog server for monitoring and audit trail	
b	Protection from unnecessary or DoS traffic by using storm control functions for unicast/multicast/broadcast.	
c	Storm control (multicast, and broadcast)	
d	Dynamic Host Configuration Protocol (DHCP) snooping or Equivalent	
e	BPDU Protection or Equivalent	
f	STP Root Protection/Equivalent	
g	Dynamic ARP Inspection/VXLAN ARP/ND suppression	

6.1.6 Access Switch - 12 Ports PoE

S. No.	General Specifications	Compliance
1.1	General Features :	
1.1.1	Switch should be 1U and rack mountable in standard 19" rack.	
1.1.3	Switch should have minimum 2GB RAM and 4GB Flash.	
1.2	Performance :	
1.2.1	Switch shall have minimum 68 Gbps of switching fabric and 50 Mpps of forwarding rate. Should be non-blocking and provide wirespeed forwarding rate.	
1.2.2	Switch shall have minimum 16 K MAC Addresses and 4000 VLAN IDs	
1.2.3	Should support minimum 10K IPv4 routes or more	
1.2.4	Switch shall have 1K or more multicast routes.	
1.2.5	Switch should support atleast 16K flow entries	
1.2.6	Switch should have 6MB or more packet buffer.	
1.3	Functionality :	
1.3.1	Switch should support IEEE Standards of Ethernet: IEEE 802.1D, 802.1s, 802.1w, 802.1x, 802.3ad, 802.3x, 802.1p, 802.1Q, 802.3, 802.1ae, 802.3u, 802.3ab, 802.3z.	
1.3.2	Switch must have functionality like static routing, RIP, REP, PIM, OSPF, VRRP, PBR and QoS features from Day1.	
1.3.3	Switch should support network segmentation that overcomes the limitation of VLANs using VXLAN and VRFs.	
1.3.4	Switch shall have 802.1p class of service, marking, classification, policing and shaping and eight egress queues.	
1.3.5	Switch should support management features like SSHv2, SNMPv2c, SNMPv3, NTP, RADIUS and TACACS+ .	
1.3.6	Switch should support IPv6 Binding Integrity Guard, IPv6 Snooping, IPv6 RA Guard, IPv6 DHCP Guard, IPv6 Neighbor Discovery Inspection and IPv6 Source Guard.	
1.3.7	Switch should support 802.1x authentication and accounting, IPv4 and IPv6 ACLs and Dynamic VLAN assignment and also have support for MACSEC-128.	
1.3.8	Switch must have the capabilities to enable automatic configuration of switch ports as devices connect to the switch for the device type.	
1.4	Interface and Power	
1.4.1	Switch shall have 12 nos. 10/100/1000 Base-T POE ports and additional 2 nos of 1G Base-T and 2 nos. of 10G SFP+ uplinks ports.	
1.4.2	Switch should have 240W of Power Budget.	
1.5	Certification:	
1.5.1	Switch shall conform to UL 60950 or IEC 60950 or CSA 60950 or EN 60950 Standards for Safety requirements of Information Technology Equipment.	
1.5.2	Switch shall conform to EN 55022 Class A/B or CISPR22 Class A/B or CE Class A/B or FCC Class A/B Standards for EMC requirements.	

6.1.7 Access Switch - 12 Ports NonPoE

S. No.	General Specifications	Compliance
1.1	General Features :	
1.1.1	Switch should be 1U and rack mountable in standard 19" rack.	
1.1.3	Switch should have minimum 2GB RAM and 4GB Flash.	
1.2	Performance :	
1.2.1	Switch shall have minimum 68 Gbps of switching fabric and 50 Mpps of forwarding rate. Should be non-blocking and provide wirespeed forwarding rate.	
1.2.2	Switch shall have minimum 16 K MAC Addresses and 4000 VLAN IDs	
1.2.3	Should support minimum 10K IPv4 routes or more	
1.2.4	Switch shall have 1K or more multicast routes.	
1.2.5	Switch should support atleast 16K flow entries	
1.2.6	Switch should have 6MB or more packet buffer.	
1.3	Functionality :	
1.3.1	Switch should support IEEE Standards of Ethernet: IEEE 802.1D, 802.1s, 802.1w, 802.1x, 802.3ad, 802.3x, 802.1p, 802.1Q, 802.3, 802.1ae, 802.3u, 802.3ab, 802.3z.	
1.3.2	Switch must have functionality like static routing, RIP, REP, PIM, OSPF, VRRP, PBR and QoS features from Day1.	
1.3.3	Switch should support network segmentation that overcomes the limitation of VLANs using VXLAN and VRFs.	
1.3.4	Switch shall have 802.1p class of service, marking, classification, policing and shaping and eight egress queues.	
1.3.5	Switch should support management features like SSHv2, SNMPv2c, SNMPv3, NTP, RADIUS and TACACS+ .	
1.3.6	Switch should support IPv6 Binding Integrity Guard, IPv6 Snooping, IPv6 RA Guard, IPv6 DHCP Guard, IPv6 Neighbor Discovery Inspection and IPv6 Source Guard.	
1.3.7	Switch should support 802.1x authentication and accounting, IPv4 and IPv6 ACLs and Dynamic VLAN assignment and also have support for MACSEC-128.	
1.3.8	Switch must have the capabilities to enable automatic configuration of switch ports as devices connect to the switch for the device type.	
1.4	Interface and Power	
1.4.1	Switch shall have 12 nos. 10/100/1000 Base-T ports and additional 2 nos. of 1G Base-T and 2 nos. of 10G SFP+ uplinks ports.	
1.5	Certification:	
1.5.1	Switch shall conform to UL 60950 or IEC 60950 or CSA 60950 or EN 60950 Standards for Safety requirements of Information Technology Equipment.	
1.5.2	Switch shall conform to EN 55022 Class A/B or CISPR22 Class A/B or CE Class A/B or FCC Class A/B Standards for EMC requirements.	

6.1.8 Access Switch - 24 Ports PoE

S. No.	General Specifications	Compliance
1.1	General Features :	
1.1.1	Switch should be 1U and rack mountable in standard 19" rack.	
1.1.2	Switch should support internal field replaceable unit redundant power supply from day 1.	
1.1.3	Switch should have minimum 2 GB RAM and 2 GB Flash.	
1.1.4	Switch should have dedicated slot/Ports for modular stacking, in addition to asked uplink ports. Should support for minimum 80 Gbps of stacking throughput with 8 switch in single stack.	
1.2	Performance :	
1.2.1	Switch shall have minimum 128 Gbps of switching fabric and 95 Mpps of forwarding rate.	
1.2.2	Switch shall have minimum 16K MAC Addresses and 4000 VLAN IDs	
1.2.3	Should support minimum 10K IPv4 routes or more	
1.2.4	Switch shall have 1K or more multicast routes.	
1.2.5	Switch should support atleast 16K flow entries	
1.2.6	Switch should support 128 or more STP Instances.	
1.2.7	Switch should have 6MB or more packet buffer.	
1.3	Functionality :	
1.3.1	Switch should support IEEE Standards of Ethernet: IEEE 802.1D, 802.1s, 802.1w, 802.1x, 802.3ad, 802.3x, 802.1p, 802.1Q, 802.3, 802.3u, 802.3ab, 802.3z.	
1.3.2	Switch must have functionality like static routing, RIP, PIM, OSPF(1000 routes), VRRP, PBR and QoS features from Day1	
1.3.3	Switch should support network segmentation that overcomes the limitation of VLANs using VXLAN and VRFs.	
1.3.4	Switch shall have 802.1p class of service, marking, classification, policing and shaping and eight egress queues.	
1.3.5	Switch should support management features like SSHv2, SNMPv2c, SNMPv3, NTP, RADIUS and TACACS+ .	
1.3.6	Switch should support IPv6 Binding Integrity Guard, IPv6 Snooping, IPv6 RA Guard, IPv6 DHCP Guard, IPv6 Neighbor Discovery Inspection and IPv6 Source Guard.	
1.3.7	Switch should support 802.1x authentication and accounting, IPv4 and IPv6 ACLs and Dynamic VLAN assignment and MACSec-128 on hardware for all ports.	
1.3.8	Switch must have the capabilities to enable automatic configuration of switch ports as devices connect to the switch for the device type.	
1.4	Interfaces	
1.4.1	Switch shall have 24 nos. 10/100/1000 Base-T PoE ports and additional 4 nos. of 10G SFP+ uplinks ports.	
1.4.2	All 24 port should support PoE (802.3af) and PoE+ (802.3at) with a PoE power budget of 370 W from day 1, Switch should capable to increase power budget upto 740W with additional Power Supply.	
1.5	Certification:	
1.5.1	Switch shall conform to UL 60950 or IEC 60950 or CSA 60950 or EN 60950 Standards for	

	Safety requirements of Information Technology Equipment.	
1.5.2	Switch shall conform to EN 55022 Class A/B or CISPR22 Class A/B or CE Class A/B or FCC Class A/B Standards for EMC (Electro Magnetic Compatibility) requirements.	
1.5.3	Switch / Switch's Operating System should be tested for EAL 2/NDPP or above under Common Criteria Certification.	

6.1.9 Access Switch - 24 Ports Non - PoE

S. No.	General Specifications	Compliance
1.1	General Features :	
1.1.1	Switch should be 1U and rack mountable in standard 19" rack.	
1.1.2	Switch should support internal field replaceable unit redundant power supply from day 1.	
1.1.3	Switch should have minimum 2 GB RAM and 2 GB Flash.	
1.1.4	Switch should have dedicated slot/Ports for modular stacking, in addition to asked uplink ports. Should support for minimum 80 Gbps of stacking throughput with 8 switch in single stack.	
1.2	Performance :	
1.2.1	Switch shall have minimum 128 Gbps of switching fabric and 95 Mpps of forwarding rate.	
1.2.2	Switch shall have minimum 16K MAC Addresses and 4000 VLAN IDs	
1.2.3	Should support minimum 10K IPv4 routes or more	
1.2.4	Switch shall have 1K or more multicast routes.	
1.2.5	Switch should support atleast 16K flow entries	
1.2.6	Switch should support 128 or more STP Instances.	
1.2.7	Switch should have 6MB or more packet buffer.	
1.3	Functionality :	
1.3.1	Switch should support IEEE Standards of Ethernet: IEEE 802.1D, 802.1s, 802.1w, 802.1x, 802.3ad, 802.3x, 802.1p, 802.1Q, 802.3, 802.3u, 802.3ab, 802.3z.	
1.3.2	Switch must have functionality like static routing, RIP, PIM, OSPF(1000 routes), VRRP, PBR and QoS features from Day1	
1.3.3	Switch should support network segmentation that overcomes the limitation of VLANs using VXLAN and VRFs.	
1.3.4	Switch shall have 802.1p class of service, marking, classification, policing and shaping and eight egress queues.	
1.3.5	Switch should support management features like SSHv2, SNMPv2c, SNMPv3, NTP, RADIUS and TACACS+ .	
1.3.6	Switch should support IPv6 Binding Integrity Guard, IPv6 Snooping, IPv6 RA Guard, IPv6 DHCP Guard, IPv6 Neighbor Discovery Inspection and IPv6 Source Guard.	
1.3.7	Switch should support 802.1x authentication and accounting, IPv4 and IPv6 ACLs and Dynamic VLAN assignment and MACSec-128 on hardware for all ports.	
1.3.8	Switch must have the capabilities to enable automatic configuration of switch ports as devices connect to the switch for the device type.	
1.4	Interfaces	
1.4.1	Switch shall have 24 nos. 10/100/1000 Base-T ports and additional 4 nos. of 10G SFP+ uplinks ports.	
1.5	Certification:	
1.5.1	Switch shall conform to UL 60950 or IEC 60950 or CSA 60950 or EN 60950 Standards for Safety requirements of Information Technology Equipment.	
1.5.2	Switch shall conform to EN 55022 Class A/B or CISPR22 Class A/B or CE Class A/B or FCC Class A/B Standards for EMC (Electro Magnetic Compatibility)	

	requirements.	
1.5.3	Switch / Switch's Operating System should be tested for EAL 2/NDPP or above under Common Criteria Certification.	

6.1.10 Access Switch - 48 Ports PoE

S. No.	General Specifications	Compliance
1.1	General Features :	
1.1.1	Switch should be 1U and rack mountable in standard 19" rack.	
1.1.2	Switch should support internal field replaceable unit redundant power supply from day 1.	
1.1.3	Switch should have minimum 2 GB RAM and 2 GB Flash.	
1.1.4	Switch should have dedicated slot/Ports for modular stacking, in addition to asked uplink ports. Should support for minimum 80 Gbps of stacking throughput with 8 switch in single stack.	
1.2	Performance :	
1.2.1	Switch shall have minimum 176 Gbps of switching fabric and 130 Mpps of forwarding rate.	
1.2.2	Switch shall have minimum 16K MAC Addresses and 4000 VLAN IDs	
1.2.3	Should support minimum 10K IPv4 routes or more	
1.2.4	Switch shall have 1K or more multicast routes.	
1.2.5	Switch should support atleast 16K flow entries	
1.2.6	Switch should support 128 or more STP Instances.	
1.2.7	Switch should have 6MB or more packet buffer.	
1.3	Functionality :	
1.3.1	Switch should support IEEE Standards of Ethernet: IEEE 802.1D, 802.1s, 802.1w, 802.1x, 802.3ad, 802.3x, 802.1p, 802.1Q, 802.3, 802.3u, 802.3ab, 802.3z.	
1.3.2	Switch must have functionality like static routing, RIP, PIM, OSPF(1000 routes), VRRP, PBR and QoS features from Day1	
1.3.3	Switch should support network segmentation that overcomes the limitation of VLANs using VXLAN and VRFs.	
1.3.4	Switch shall have 802.1p class of service, marking, classification, policing and shaping and eight egress queues.	
1.3.5	Switch should support management features like SSHv2, SNMPv2c, SNMPv3, NTP, RADIUS and TACACS+ .	
1.3.6	Switch should support IPv6 Binding Integrity Guard, IPv6 Snooping, IPv6 RA Guard, IPv6 DHCP Guard, IPv6 Neighbor Discovery Inspection and IPv6 Source Guard.	
1.3.7	Switch should support 802.1x authentication and accounting, IPv4 and IPv6 ACLs and Dynamic VLAN assignment and MACSec-128 on hardware for all ports.	
1.3.8	Switch must have the capabilities to enable automatic configuration of switch ports as devices connect to the switch for the device type.	
1.4	Interfaces	
1.4.1	Switch shall have 48 nos. 10/100/1000 Base-T PoE ports and additional 4 nos. of 10G SFP+ uplinks ports.	
1.4.2	All 24 port should support PoE (802.3af) and PoE+ (802.3at) with a PoE power budget of 740 W from day 1, Switch should capable to increase power budget upto 1440W with additional Power Supply.	
1.5	Certification:	
1.5.1	Switch shall conform to UL 60950 or IEC 60950 or CSA 60950 or EN 60950 Standards for	

	Safety requirements of Information Technology Equipment.	
1.5.2	Switch shall conform to EN 55022 Class A/B or CISPR22 Class A/B or CE Class A/B or FCC Class A/B Standards for EMC (Electro Magnetic Compatibility) requirements.	
1.5.3	Switch / Switch's Operating System should be tested for EAL 2/NDPP or above under Common Criteria Certification.	

6.1.1.1 Access Switch - 24 Ports Multigig PoE – Type I

S. No.	General Specifications	Compliance
1.1	General Features :	
1.1.1	Switch should be 1U and rack mountable in standard 19" rack.	
1.1.2	Switch should support internal field replaceable redundant power supply from day 1.	
1.1.3	Switch should have minimum 2 GB RAM and 2 GB Flash.	
1.1.4	Switch should have dedicated slot for modular stacking, in addition to uplink ports. Should support minimum 40 Gbps of stacking throughput with 8 switch in single stack.	
1.2	Performance :	
1.2.1	Switch shall have minimum 272 Gbps of switching fabric and 214 Mpps of forwarding rate.	
1.2.2	Switch shall have minimum 16K MAC Addresses and 250 active VLAN.	
1.2.3	Should support minimum 11K IPv4 routes or more	
1.2.4	Switch shall have 1K or more multicast routes.	
1.2.5	Switch should support atleast 16K flow entries	
1.2.6	Switch should support 128 or more STP Instances.	
1.2.7	Switch should have 6MB or more packet buffer.	
1.3	Functionality :	
1.3.1	Switch should support IEEE Standards of Ethernet: IEEE 802.1D, 802.1s, 802.1w, 802.1x, 802.3ad, 802.3x, 802.1p, 802.1Q, 802.3, 802.3u, 802.3ab, 802.3z.	
1.3.2	Switch must have functionality like static routing, RIP, PIM, OSPF, VRRP, PBR and QoS features from Day1	
1.3.3	Switch should support network segmentation that overcomes the limitation of VLANs using VXLAN and VRFs.	
1.3.4	Switch shall have 802.1p class of service, marking, classification, policing and shaping and eight egress queues.	
1.3.5	Switch should support management features like SSHv2, SNMPv2c, SNMPv3, NTP, RADIUS and TACACS+ .	
1.3.6	Switch should support IPv6 Binding Integrity Guard, IPv6 Snooping, IPv6 RA Guard, IPv6 DHCP Guard, IPv6 Neighbour Discovery Inspection and IPv6 Source Guard.	
1.3.7	Switch should support 802.1x authentication and accounting, IPv4 and IPv6 ACLs and Dynamic VLAN assignment and MACSec-128 on hardware for all ports.	
1.3.8	Switch must have the capabilities to enable automatic configuration of switch ports as devices connect to the switch for the device type.	
1.3.9	During system boots, the system's software signatures should be checked for integrity. System should capable to understand that system OS are authentic and unmodified, it should have cryptographically signed images to provide assurance that the firmware & BIOS are authentic.	
1.4	Interfaces	

1.4.1	Switch shall have 16 nos. 10/100/1000 Base-T ports and additional 8 nos. port supporting 100MB/1G/2.5G/5G/10G Additional 4 nos. SFP+ uplinks ports.	
1.4.2	All 24 port should support PoE (802.3af) and PoE+ (802.3at) with a PoE power budget of 370 W.	
1.5	Certification:	
1.5.1	Switch shall conform to UL 60950 or IEC 60950 or CSA 60950 or EN 60950 Standards for Safety requirements of Information Technology Equipment.	
1.5.2	Switch shall conform to EN 55022 Class A/B or CISPR22 Class A/B or CE Class A/B or FCC Class A/B Standards for EMC (Electro Magnetic Compatibility) requirements.	
1.5.3	Switch / Switch's Operating System should be tested for EAL 2/NDPP or above under Common Criteria Certification.	

6.1.12 Access Switch - 24 Ports Multigig PoE – Type II

S. No.	General Specifications	Compliance
1.1	General Features :	
1.1.1	Switch should be 1U and rack mountable in standard 19" rack.	
1.1.2	Switch should support internal field replaceable redundant power supply from day 1.	
1.1.3	Switch should have minimum 2 GB RAM and 2 GB Flash.	
1.1.4	Switch should have dedicated slot for modular stacking, in addition to uplink ports. Should support for minimum 800 Gbps of stacking throughput with 8 switch in single stack.	
1.2	Performance :	
1.2.1	Switch shall have minimum 800 Gbps of switching fabric and 320 Mpps of forwarding rate.	
1.2.2	Switch shall have minimum 16K MAC Addresses and 250 active VLAN.	
1.2.3	Should support minimum 11K IPv4 routes or more	
1.2.4	Switch shall have 1K or more multicast routes.	
1.2.5	Switch should support atleast 16K flow entries	
1.2.6	Switch should support 128 or more STP Instances.	
1.2.7	Switch should have 6MB or more packet buffer.	
1.3	Functionality :	
1.3.1	Switch should support IEEE Standards of Ethernet: IEEE 802.1D, 802.1s, 802.1w, 802.1x, 802.3ad, 802.3x, 802.1p, 802.1Q, 802.3, 802.3u, 802.3ab, 802.3z.	
1.3.2	Switch must have functionality like static routing, RIP, PIM, OSPF, VRRP, PBR and QoS features from Day1	
1.3.3	Switch should support network segmentation that overcomes the limitation of VLANs using VXLAN and VRFs.	
1.3.4	Switch shall have 802.1p class of service, marking, classification, policing and shaping and eight egress queues.	
1.3.5	Switch should support management features like SSHv2, SNMPv2c, SNMPv3, NTP, RADIUS and TACACS+ .	
1.3.6	Switch should support IPv6 Binding Integrity Guard, IPv6 Snooping, IPv6 RA Guard, IPv6 DHCP Guard, IPv6 Neighbour Discovery Inspection and IPv6 Source Guard.	
1.3.7	Switch should support 802.1x authentication and accounting, IPv4 and IPv6 ACLs and Dynamic VLAN assignment and MACSec-128 on hardware for all ports.	

1.3.8	Switch must have the capabilities to enable automatic configuration of switch ports as devices connect to the switch for the device type.	
1.3.9	During system boots, the system's software signatures should be checked for integrity. System should be capable to understand that system OS are authentic and unmodified, it should have cryptographically signed images to provide assurance that the firmware & BIOS are authentic.	
1.4	Interfaces	
1.4.1	Switch shall have 24 nos. port supporting 100MB/1G/2.5G/5G/10G.	
1.4.2	All 24 port should support PoE (802.3af) and PoE+ (802.3at) with a PoE power budget of 735 W.	
1.5	Certification:	
1.5.1	Switch shall conform to UL 60950 or IEC 60950 or CSA 60950 or EN 60950 Standards for Safety requirements of Information Technology Equipment.	
1.5.2	Switch shall conform to EN 55022 Class A/B or CISPR22 Class A/B or CE Class A/B or FCC Class A/B Standards for EMC (Electro Magnetic Compatibility) requirements.	
1.5.3	Switch / Switch's Operating System should be tested for EAL 2/NDPP or above under Common Criteria Certification.	

6.1.13 Access Switch - 48 Ports Multigig PoE

S. No.	General Specifications	Compliance
1.1	General Features :	
1.1.1	Switch should be 1U and rack mountable in standard 19" rack.	
1.1.2	Switch should support internal field replaceable redundant power supply from day 1.	
1.1.3	Switch should have minimum 2 GB RAM and 2 GB Flash.	
1.1.4	Switch should have dedicated slot for modular stacking, in addition to asked uplink ports. Should support for minimum 480 Gbps of stacking throughput with 8 switch in single stack.	
1.2	Performance :	
1.2.1	Switch shall have minimum 640 Gbps of switching fabric and 470 Mpps of forwarding rate.	
1.2.2	Switch shall have minimum 16K MAC Addresses and 250 active VLAN.	
1.2.3	Should support minimum 11K IPv4 routes or more	
1.2.4	Switch shall have 1K or more multicast routes.	
1.2.5	Switch should support atleast 16K flow entries	
1.2.6	Switch should support 128 or more STP Instances.	
1.2.7	Switch should have 6MB or more packet buffer.	
1.3	Functionality :	
1.3.1	Switch should support IEEE Standards of Ethernet: IEEE 802.1D, 802.1s, 802.1w, 802.1x, 802.3ad, 802.3x, 802.1p, 802.1Q, 802.3, 802.3u, 802.3ab, 802.3z.	
1.3.2	Switch must have functionality like static routing, RIP, PIM, OSPF, VRRP, PBR and QoS features from Day1	
1.3.3	Switch should support network segmentation that overcomes the limitation of VLANs using VXLAN and VRFs.	
1.3.4	Switch shall have 802.1p class of service, marking, classification, policing and shaping and eight egress queues.	

1.3.5	Switch should support management features like SSHv2, SNMPv2c, SNMPv3, NTP, RADIUS and TACACS+ .	
1.3.6	Switch should support IPv6 Binding Integrity Guard, IPv6 Snooping, IPv6 RA Guard, IPv6 DHCP Guard, IPv6 Neighbour Discovery Inspection and IPv6 Source Guard.	
1.3.7	Switch should support 802.1x authentication and accounting, IPv4 and IPv6 ACLs and Dynamic VLAN assignment and MACSec-128 on hardware for all ports.	
1.3.8	Switch must have the capabilities to enable automatic configuration of switch ports as devices connect to the switch for the device type.	
1.3.9	During system boots, the system's software signatures should be checked for integrity. System should capable to understand that system OS are authentic and unmodified, it should have cryptographically signed images to provide assurance that the firmware & BIOS are authentic.	
1.4	Interfaces	
1.4.1	Switch shall have 48 nos. port supporting 100MB/1G/2.5G/5G.	
1.4.2	All 48 port should support PoE (802.3af) and PoE+ (802.3at) with a PoE power budget of 640 W.	
1.5	Certification:	
1.5.1	Switch shall conform to UL 60950 or IEC 60950 or CSA 60950 or EN 60950 Standards for Safety requirements of Information Technology Equipment.	
1.5.2	Switch shall conform to EN 55022 Class A/B or CISPR22 Class A/B or CE Class A/B or FCC Class A/B Standards for EMC (Electro Magnetic Compatibility) requirements.	
1.5.3	Switch / Switch's Operating System should be tested for EAL 2/NDPP or above under Common Criteria Certification.	

6.1.14 10G SM Transceiver

S. No	Minimum Specifications	Compliance
1	Speed 10Gbps	
2	Single Mode	
3	Make: Same as switch OEM	
4	Distance: 10KM	

6.1.15 NMS

S. No	Description	Compliance
1	Solution should have single pane of glass to discover, provision, monitor, manage, analyze and troubleshoot the network	
2	Solution should design the network in a hierarchal manner along with automated provisioning of the devices	
3	Solution should have self-learning capabilities like discovering the devices, getting on boarded using Plug and play and creating a topology automatically	
4	Solution should provide complete inventory of network as well as should do the software or firmware image management	
5	Solution should provide support to upgrade and downgrade the firmware	
6	Solution should support workflows defined to complete each configurations step by step e.g. RMA process	
7	Solution should support capabilities like AI/ML to dynamically filter the inventory and provide impacted devices list due to vulnerability.	
8	Solution should have capabilities to monitor the health of network devices, clients connected to the devices and application accessed over the network.	
9	Solution should have capabilities to alert/alarm when the issues detected over the network e.g. device health, link utilization etc. etc. and it should be shown under category like P1, P2	
10	Solution should have capabilities to analyze the database of client's connectivity, devices statistics, applications performance statistics and need to come up with remediation plan in minutes against the issues.	
11	Solution should support Application visibility using DPI, Client level visibility and device health visibility.	
12	Solution should have capabilities like sensors for wired and wireless network to simulates real-world client experiences. Sensors can provide pro-active information about the health of your network.	
13	Solution should support wireless sensor in terms of AP to do the synthetic probing to capture the health of network pro-actively	
14	<p>Solution should support below for switching</p> <ul style="list-style-type: none"> • Client or device DHCP • Client or device DNS • Client authentication or authorization Switch • CPU, memory, temperature • Line card • Modules • Power over Ethernet (PoE) power • Ternary Content-Addressable Memory (TCAM) table 	
15	Solution should provide the dashboard capability to show case the wireless readiness status, clients connected using 802.11n; 802.11ac or 802.11ax and location level statistics	
16	Solution should have capabilities like PoE Analytics which provides visibility on the power load and power availability per switch and per port.	

17	Solution should have capabilities to trace the path to reach the destination across the network to understand any security filters available across the path	
18	Solution should have capabilities to go back in time and see the cause of a network issue	
19	Solution should have capabilities to capture the wireless network information proactively to analyze wireless performance per access point or per Wi-Fi client.	
20	Solution should be capable to provide Weekly and daily report providing executives a summary of how their network is performing with insights into network devices, clients, and applications.	
21	Solution should have capabilities to classify thousands of network and home-grown applications and network traffic. (Known and custom applications)	
22	Solution should support role-based access control (RBAC)	
23	Solution should support out of box integration with ITSM using generic APIs	
24	Solution should support out of box integration with IPAM using generic APIs	
25	Dashboard should have option of time slider of 24 hrs to check information for a specific time period.	
26	It should have a customizable dashboard with option to build hierarchical/ building view dashboard.	
27	Dashboard should be able to provide root cause analysis and recommendations to fix problem.	
28	Dashboard should provide user experience visibility like Throughput analysis, Roaming pattern analysis, sticky client information, slow roaming, dual band clients prefer 2.4 Ghz.	
29	Dashboard should provide network coverage and capacity information like coverage hole, client capacity, Radio utilization.	

6.1.16 Server

S. No.	Description		Compliance
1	Number of processors	Two nos. of Intel Xeon Gold processor or better	
2	Processor core	16 core for each processor & Processor cache 30MB L3 or better	
3	Chipset	Intel chipset compatible with the offered processors.	
4	Expansion Slots	PCIe 3.0 Minimum 3 nos.	
5	Processor speed	3.1 GHz or better	
6	Form factor	1U/2U	
7	Form factor chassis	Rack	
8	Storage	The server should Support upto 8 hot-swappable SAS, NL-SAS and SSD drives.	
9		Server should be configured with 6 Nos 2.4 TB 12G SAS from day one.	
10		The Server RAID controller should support the following configurations RAID 0, 1, 5, 6, 10, 50, and 60	
11	Memory	Should have at least 24 DIMM slots per server and support minimum up to 1.5TB of DDR4 2666 MHz memory.	
12		The Server should be configured with 64 GB of DDR4 Memory from day one	
13		Support for advanced memory redundant technologies like Advanced error-correcting code (ECC) and memory mirroring.	
14	System fan features	Hot plug redundant standard	
15	Graphic card	Integrated graphic controller or better	
16	Network Controller	4 X 1Gb Ethernet Network Controller.	
17	Power Supply	Should have redundant hot swap power supply	
18	Security	The server should provide cryptographic firmware updates	
19		Capable to stop execution of the BIOS	
20		Server should provide Anti-counterfeit	
21		The server should provide hardware policy-based security	
22		The server should provide rack server intrusion detection	
23		The server should provide Hardware root of trust	
24		The server should provide system lock down	
25	Management	Should support out of band upgrades, Agentless out-of-band management, integrated diagnostics and Power monitoring and reporting.	
26		The system should provide management of multiple servers from single console	
27		The system should provide hardware profile deployment (Single server	

		OS group of servers)	
28		The server should support industry standard management protocols like IPMI v2 and SNMP v3	
29		One 1-Gbps RJ-45 management port	
30		The server should support multiple management interfaces including web user interface and command line interface.	
31	Ports	Should have the following ports for server connectivity	
32		● 1 serial port	
33		● 4 USB 3.0/2.0 ports	
34	Operating System	Windows Server 2019 Standard Edition with 2 Hyper-V containers and all physical cores in the server licensed.	
35	Remote management	Management of the server over LAN, WAN with SSL encryption, virtual media license and KVM over IP	
36	Accessories	The server should be supplied along with software utilities for system configuration, OS installation and system information, cables, user manual, rack mount kit. Driver software for all The adapters as per The configuration and required operating system	
37	Warranty	5 years Comprehensive Onsite Warranty	

6.2 PASSIVE COMPONENTS

6.2.1 CAT6A UTP Outdoor Jelly Filled Double Jacketed CABLE

Details	Specification	Compliance
Type	23 AWG solid bard copper, Unshielded Twisted 4 Pair, Category 6A, confirming to TIA 568.C.2, Class EA - ISO/IEC 11801:2002 Amendment 2. Third party channel verified to TIA/EIA-568-C.2, Category 6A	
Conductors	Solid Bare Copper 23 AWG	
Insulation	Polyolefin	
Pair Separator	X-spline Central Member	
Filling Compound	Jelly Filled	
Barrier Material	Barrier Tape - Tri-Laminate - for improved heat transfer and achieves uniform heat flow dissipation to eliminate hotspots in cable bundles when delivering remote power.	
Inner and Outer Jacket	Polyolefin/LLDPE and Polyolefin respectively	
Applicable Standards	Category 6A - TIA 568.C.2 ANSI/ICEA S-99-689 ANSI/ICEA S-107-704 Paragraph 8.2.1 Water Penetration ANSI/ICEA S-56-434 Outdoor Use POE per IEEE 802.3af & POE+ per IEEE 802.3at-2009 ISO/IEC 11801 ed 2 Amendment 2:2010 Class EA -40C Cold Bend Compliance Per UL1581 Water Penetration per GR 421-CORE para. 4.3.5.1. and ANSI/ICEA S-107-704 Para. 8.2.1.	
Suitable Applications:	OSP Cable, 10 Gigabit Ethernet, Outdoor, Aerial, Burial, Sunlight Resistant, Noisy Environments, PoE, PoE+	
Guaranteed Bandwidth	500 Mhz for 100 MT Channel	
Packing	Box of 305 meters	
Cable Outer Diameter	9.2 mm	
Delay Skew	45 ns @ 100M	
Bend Radius (Installation)	92 mm	
Maximum Conductor DC Resistance:	DCR @ 20°C (Ohm/100 m) = 7.9	
Maximum Delay:	Delay (ns/100 m) = 537	
Nom. Mutual Capacitance	Capacitance (pF/m) < 56	
Nom. Velocity of Propagation	65 %	
Temperature Range	-40 Deg C to +75 Deg C	

Operation		
Performance characteristics @ 500 MHz	Max. Attenuation: 45.4 dB/100m Min. PS NEXT : 31.8 dB Min. Return Loss: 15.2 dB Min. PSACR : 0.9 dB @ 300Mhz Min. PS ANEXT: 52.0 dB Min. PS AACRF: 24.2 dB	
PoE Compatibility	PoE Type 1 (15 W), Type 2 (30 W)	
ELV	EU Directive 2000/53/EC	
Ripcord	Should be available under Outer Jacket	
RoHS and WEEE and BFR	It should be RoHS , WEEE & BFR Complied	
Jacket Color	Black (Sunlight Resistant)	

6.2.2 CAT6A U/UTP LSZH CABLE

Details	Specification	Compliance
Type	23 AWG Solid Bare Copper, Unshielded Twisted 4 Pair, Category 6A, confirming to TIA 568.2.D, Class EA - ISO/IEC 11801:2002	
Conductors	Solid Bare Copper 23 AWG	
Insulation	Polyolefin	
Jacket	LSZH jacket complying to: Acid Gas Emission pH per IEC 60754-1: ≥ 4.3 Acid Gas Conductivity per IEC 60754-2: $\leq 10\mu\text{s}/\text{mm}$ Smoke density IEC 61034-2: $\geq 60\%$ Light Transmittance Flame Test: IEC 60332-3-1 Third Party Test Reports of all above parameters should be available in technical sheet	
Pair Separator	+ Shape Spline	
Suitable Applications:	Premise Horizontal Cable, 10 Gigabit Ethernet, 100BaseTX, 100BaseVG ANYLAN, 155ATM, 622ATM, NTSC/PAL Component or Composite Video, AES/EBU Digital Audio, AES51, RS-422, Noisy Environments, PoE, PoE+, PoE++	
Guaranteed Bandwidth	500 Mhz for 100 MT Channel	
Packing	Box of 305 meters	
Cable Outer Diameter	7.5 mm Max.	
Max. Delay Skew	45 ns @ 100M	
Bend Radius (Installation)	50 mm	
Maximum Conductor DC Resistance:	DCR @ 20°C (Ohm/100 m) < 9.5	
Third Party Verification	<ul style="list-style-type: none"> ETL/Intertek Test Report for compliance to EN 50173-1 & ISO/IEC 11801-1 for Min. 500Mhz or Higher. ETL/Intertek Test Report for Alien crosstalk (6 around 1) for ANEXT, AFEXT, PS ANEXT. ETL/Intertek Test Report for testing at elevated temperature of 40 Deg C and 60 Deg C respectively min. 500 Mhz or higher for IL (< 45.5 dB), Propagation Delay (< 538ns) and Delay Skew (< 45 ns) ETL/Intertek 4 connector Channel Test Report All above test reports to be submitted along with bid 	
Nom. Mutual Capacitance	Capacitance (nF/100m) < 5.6	

Temperature Operation	Range	-20 Deg C to +60 Deg C	
Performance characteristics @ 500 MHz		Max. Attenuation: 45.5 dB/100m Min. NEXT : 34.5 dB Min. PS NEXT : 31.5 dB Min. Return Loss: 17.0 dB Min. PSACRF : 11.0 dB	
IEEE Requirement		IEEE 802.3bt Type 1, Type 2, Type 3, Type 4	
ETL/Intertek Report Submission	Test	Average DCR <= 7.5 Ohms @ 20 Deg C, Resistance Unbalance <=1%, Max. Capacitance Unbalance <= 100pf/100m	
ETL/Intertek Tested		TIA 568.2.D (Test Report to be submitted)	
RoHS		Yes	

6.2.3 Cat6A Unshielded Modular Jack

Parameters	Specifications	Compliance
Type	Modular Jacks shall meet and exceed channel specification of ANSI/TIA/EIA-568-C.2 Category 6a and ISO/IEC 11801:2002/Amd 1:2002 Ed2 when used as a component in a properly installed UTP channel.	
Front Connection	RJ 45 : 50uin Gold plated contacts over Nickel	
Rear Connection	Copper alloy, Gold plated contacts over Nickel or IDC	
Connector Body	PBT glass reinforced UL94V-0 or Plastic	
Accessories	Jack should support uniform hassle free termination technology and be able to ensure performance in each termination without dependency on expertise of technician.	
Termination Interface	Front Mated Connection: 750 Cycles Min. Rear Mated Connection: 20 Cycles Min.	
IEEE Specification (PoE)	IEEE 802.3bt type 3 and 4 (up to 100W) UPOE (up to 60W) and Power over HDBase-T (up to 100W)	
Performance tests	Modular Jacks shall be tested for performance to ANSI/TIA/EIA-568-C.2	
Guaranteed Bandwidth	Min. 500 Mhz or higher Guaranteed Bandwidth for 100 MT Channel Link	
Approvals	UL Listed, UL2043 Air Handling Spaces	
UL Rating	UL 94V-0	
Other Specifications	UL 1863, IEC 60603-7, FCC part 68-F	
RoHS	EU Directive 2002/95/EC Compliant	
Feature	The jacks shall not have an integrated spring shutter as the shutter malfunctions and causes operational issues in Panel.	
Operating Temperature	-40° to 70°C	
Dielectric Strength	1,000 V RMS @ 60 Hz for 1 minute (Signals to Ground)	
Electrical Performance @ 500 Mhz or higher	Insertion Loss: Max. 0.48 dB NEXT: Min. 37.0 dB FEXT: Min. 31.1 dB RL: Min. 12.9 dB PSANEXT: Min 56.0 dB PSACRF: Min 56.0 dB Balanced TCL: Min 19.0 dB	
Termination Process	Termination of cable on IO through Universal Termination Tool to minimize any manual termination like punch down. All the four pairs should get crimped and cut together with the help of the tool. Pairs should not be separated in termination process to avoid any cross talk issue at Jack. Tool-less jack is not required because the tool-less jack is installer dependent, whereas the termination using a tool has consistent terminations irrespective of the installer.	

Cat6A Jack	It should be covered under 25 year warranted solution from OEM.	
Third Party Test Report	Enclose 4 Connector ETL/UL/3P Test Report ANSI/TIA – 568 Cat6 6A, ISO/IEC 11801 (Class Ea), EN 50173 (Class Ea) and IEEE 802.3-2012.	

6.2.4 Cat 6A Unshielded Patch Cords, LSZH, ETL Tested

Parameters	Specifications	Compliance
Type	Modular Cord shall meet and exceed channel specification of ANSI/TIA/EIA-568-B.2 Category 6a and ISO/IEC 11801 2nd edition (2002) & Amendment 2 (2010) up to 500 MHz when used as a component in a properly installed UTP channel. It should also comply to EN 50173-1 (2002) & EN 50173-1 Amendment 1 (2009).	
Conductor	Stranded copper ETP, 7/26AWG	
Insulation	Foam Polyethylene/PE (1.05 mm +/- 0.05 mm)	
Plug Boot	Clear boot with PVC material	
Plug Housing	Polycarbonate (PC)	
Plug contact blade	Phosphor bronze plated with 1.27um gold over 2.54um nickel undercoat	
Insertion Life	750 Cycles	
Operating/Storage Temperature Range	-20 to +60 Deg C	
Channel compliance certificate	Certificate by Intertek (ETL)/UL/3P for the 4-Connectors and 3 Connectors channel testing to the Cat 6A Cabling system as per the ANSI/TIA 568 C.2 standards, ISO/IEC 11801 and EN 50173-1. Document to be submitted.	
Guaranteed Bandwidth	500 Mhz or Better Guaranteed Bandwidth	
Sheath Material	LSZH	
Flame Rating	IEC 60332-3-22	
OD	6.1 ± 0.3 mm	

6.2.5 Face Plate, UK Style, Square with Shutters

Details	Specification	Compliance
Type	Simplex/Duplex/Quad	
Material	Fire -retardant Plastic, ABS, White color, UK Style with Shutters	
Acceptability	Should be able to accept Cat6A, Cat6 and Cat5e information outlets	
UL Flame Test (Material)	UL94V0	
Compliant	RoHS	
Dimensions	(H x W x D) 86 x 86 x 10 mm	

6.2.6 24 Port CAT 6A Patch Panel

Parameters	Specifications	Compliance
CAT 6A patch Panel	Conforming to ANSI/TIA/EIA-568 C.2 latest or ISO/IEC:11801 latest	
Patch panel suitability for	Cat5E, CAT6and Cat6A UTP (shielding is not acceptable)	
Height of patch panel	1U/2U	
No. of ports (RJ 45)	For 1U 24 Ports Loaded/Unloaded (Unloaded + Jacks is acceptable) For 2U 48 Ports Loaded/Unloaded (Unloaded + Jacks is acceptable)	
Cable Management (Rear side)	With Rear Cable Management Bar and 2 Rear Cable Management Bracket	
Cable Management (Front side)	6 Port Removable angled inserts with ability to flip left or right as per requirements	
Applications	0BASE-T, 100BASE-TX Fast Ethernet, 1000BASE-T (IEEE802.3) , 100VG-AnyLAN (IEEE802.12), 250 MHz Broadband Video, Voice, T1, ISDN, 155/622 Mbps ATM , Power over Ethernet (POE, POE+, 4 PPOE)	
Modular plug fitting (RJ 45)	Assembly of 6 jacks/ 4 assemblies in 24 port 1U panel	
Plug insertion durability	≥ 750 mating cycles"	
Safety Listing for Jacks	c(UL)us Listed	
Other Specification for Jacks	UL 1863, IEC 60603-7, FCC part 68-F	
UL Flame Test for Jacks	UL2043 Air Handling Spaces	
Termination Process	Termination of cable on IO through Universal Termination Tool to minimize any manual termination like punch down. All the four pairs should get crimped and cut together with the help of the tool. Pairs should not be separated in termination process to avoid any cross talk issue at Jack. Tool-less jack is not required because the tool-less jack is installer dependent, whereas the termination using a tool has consistent terminations ir-respective of the installer.	

6.2.7 6 / 12/24 Core Singlemode (9/125µm) G657-A1 Bend Insensitive Fibre optic Cable

Details	Specification	Compliance
Cable	6/12/24 Core Singlemode 9/125, Central Loose Tube Cables, High mechanical and full rodent protection provided by Outdoor – Corrugated Steel Tape Armor (CST), complying to both 9/125 ITU G.652D & G.657A1 BI standards	
Application	Cable should be suitable for Structured (premises) wiring systems: For outdoor use in structured (data) wiring systems such as industrial backbone, campus backbone, building backbone (riser). Suitable for direct burial. Easy to install in ducts, tunnels and trenches.	
Jacket	Black UV resistant PE outer jacket. Water swellable E-glass yarns as strength members and for the longitudinal watertightness , surrounded by swelling tape.	
Loose Tube Construction	Std. plywood reel: \varnothing 1000 * 588 mm, Central tube, jelly filled (non-dripping and silicon-free).	
Optical Properties	Core: 9.2 +/- 0.4 μ m Cladding: 125 +/- 0.7 μ m Loose Tube fibres: \varnothing 250 \pm 15 μ m 1310 Wavelength (nm): 0.33 / 0.34 Attenuation typical/ max. (dB/km) 1550 Wavelength (nm): 0.18 / 0.19 Attenuation typical/ max. (dB/km) 1625 Wavelength (nm): 0.20 / 0.24 Attenuation typical/ max. (dB/km) Dispersion (ps/ (nm-km)) @ 1310 nm: \leq 3.2 Dispersion (ps/ (nm-km)) @ 1550 nm: \leq 17 Cutoff Wavelength : \leq 1260 nm PMD (ps/km) : \leq 0.06	
Temperature Range	Storage Temperature Range: -30 to +70 °C Installation Temperature Range: -5 to +50 °C Operating Temperature Range: -30 to +70 °C	
Physical Properties	Watertightness according to IEC 60794-1-22-F5 Crush resistance according to IEC 60794-1-21-E3	
	Bending radii tube (Installation & Operation) >25 mm Cable Min. Bend Radius Operation (Long Term): 20 x Cable Diam. Cable Min. Bend Radius Installation (Short Term): 20 x Cable Diam. Cable Max. Tensile Strength Operation (Long Term): 730 N Cable Max. Tensile Strength Installation (Short Term): 2220 N Cable Max. Crush Resistance Operation (Long Term): 11 kN/m Cable Max. Crush Resistance Installation (Short Term): 22 kN/m Nominal Cable OD: 9.3 mm Max.	
Bend Insensitive Optical Properties	Maximum Attenuation increase for Bend Insensitive Fibers 9/125 G.657A1 Bend Insensitive 1550 (nm): 0.03dB (Turns 100 Radius 30 mm), 0.25 dB (Turns 10 Radius 15 mm), 0.75 dB (Turns 1 Radius 10 mm) 1625 (nm): 0.03 dB (Turns 100 Radius 30 mm), 1.0 dB (Turns 10 Radius 15 mm), 1.5 dB (Turns 1 Radius 10 mm)	

6.2.8 24/48Fiber 1U Rack Mount Fiber Enclosure (LIU), Splice Trays and Adapter

Details	Specification	Compliance (YES/NO)
Fiber Management Shelf	The fiber management shelf shall have compact design and be ideal for high density front patching applications.	
	Should be fully loaded and factory fitted assembly with no assembling required during installation at site	
Fiber Interface Unit	Should be mounted directly on any 19" rack or cabinet. It should be able to accommodate a variety of Fiber connectors and terminated to fiber cables using Splicing or other methods.	
Type	Fiber LIU should be 1U (1.75"), 19 Inch Rack Mount.	
	12/24/48 Port should be available in 1U Rack Mount LIU.	
	LC Type Connectors will be required.	
Features & Compatibility	Each 1U LIU should be able to accommodate atleast 48 fibers in LC type connectors.	
	24/48 Fiber Splice trays should loaded in LIU with Pigtails, Splice Tubes, Min. 2 x PG13.5 Gland, Cable Ties and Velcro Straps	
	Panel Material – Powdered Coated Steel	
	Couplers in adapter strip should be Blue Colored	
	Operating Temp Range: -10°C to +60°C	
	Storage Temp Range: -40°C to +70°C	
	EU Directive 2011/65/EU (ROHS II)	
Cable entry ports	Min 4 cable entry points at rear of shelf, sealed with rubber grommets.	
Drawer style shelf	o Easy access to splicing tray and connectors	
	o Should have front locking latches on both side of shelf, for preventive sliding	
Accessories	Fiber management guides, secure tie downs and all splicing accessories like sleeves, cleaning kits, cable markers and grommet shall be packed with panel kit.	
	Pre-loaded with labeling strips, 2 grounding lugs	
Dust protection.	Sealed cable inlets for dust and rodent protection. Front adapters with dust caps.	
Material	Min 1.6mm CRCA Sheet steel with powder coating	
Fiber / buffer tube storage	Min of 320 mm depth to accommodate fiber slack and buffer tube storage space.	
Pigtails loaded in Shelf:	LC type SM, 900 micron cordage.	

6.2.9 Fiber Patch Cords, LC-LC / SC-LC / SC-SC Duplex, Singlemode OS2, 3MT

Details	Specification	Compliance (YES/NO)
Type	2mm Duplex Zipcord.	
	Singlemode OS2	
Outside Diameter	(Duplex): 2.0mm x 3.0mm or as per design	
Jacket Material	LSZH (IEC 60332-3, IEC 60754-2, IEC 61034-2)	
Length	3 MT	
Minimum Cable Retention Strength	2.0/3.0mm: 200 N Tensile Strength 2.0/3.0mm: 1000 N Crush Resistance	
Insertion Loss	≤ 0.3 dB	
Return Loss	≥ 55 dB @ 1310nm	
RoHS Certified	Yes	
Cable Standards	IEC 60794, IEC 60332, UL 1685, NFPA 262	
Connector Standards:	IEC 61754, TIA 604	

6.2.10 Pigtail, LC/SC Type, Single mode OS2, 2 MT

Details	Specification	Compliance
Type	Optical Fiber Pigtail LC - Simplex, Single mode OS2 , 2 Mtr	
Feature	Tight Buffer construction (0.9mm) Single mode OS2 should be of min 2 Meter Length	
Standard	Optical Fiber Pigtail should comply with TIA 568 3 D. It shall be mentioned in technical datasheet.	
Minimum Cable Retention Strength	Optical Fiber Pigtail should have Max. Tensile Strength of 30N (Short Term).	
	Optical Fiber Pigtail should have Max. Crush Resistance of 100 N/100 (Short Term).	
Optical Performance	Optical Fiber Pigtail should have Insertion Loss of $\leq 0.3\text{dB}$ @ 1310nm for OS2 as per TIA/EIA 568-C.3	
	Optical Fiber Pigtail should have Return Loss of $\geq 55\text{dB}$ @ 1310nm for OS2 as per TIA/EIA 568-C.3	
RoHS Certified	RoHS Complaint	

7 Terms & Conditions of Contract

7.1 Arbitration

All disputes arising out of this contract shall be referred to the Director, IIM Raipur whose decision shall be final and binding on both parties.

7.2 Special Terms and Condition:

In view of office memorandum F.No.6/18/2019-PPD dated 23rd July 2020 issued by Public Procurement Division, Department of Expenditure, Ministry of Finance, all tenderers, vendors or service provider should comply to the restrictions under rule 144 (xi) of General Financial Rules (GFRs). If any of the bidder fail to comply then their bids shall be rejected.

7.3 Clarification of Offers

To assist in the scrutiny, evaluation and comparison of offers, IIM Raipur may, at its discretion, ask (by email) some or all bidders for clarifications with regards to their offer. The request for such clarifications and the response will necessarily be in writing (by email). Failure of a Bidder to submit additional information or clarification as sought by the institute within the prescribed period will be considered as a non-compliance and the proposal may get evaluated based on the limited information furnished along with the bid proposal.

7.4 Extension of Delivery Period and Liquidated Damages

Buyer may, on the request of the Seller or otherwise, extend the delivery date suitably subject to the following conditions:

The original Delivery Period may be re-fixed by the Buyer without any Liquidated damages subject to Force Majeure conditions mentioned below and also on the ground/reasons of delay attributable to the Buyer.

7.5 Liquidated Damages:

If the Seller/Service Provider fails to deliver any or all of the Goods/Services within the original/re-fixed delivery period(s) specified under Delivery Schedule this tender, the Buyer will be entitled to deduct/recover the Liquidated Damages for the delay, unless covered under Force Majeure conditions aforesaid, @ 0.1% of the contract value of delayed quantity per day of delayed period as pre estimated damages not exceeding 10% of the contract value of delayed quantity without any controversy/dispute of any sort whatsoever.

7.6 Force Majeure Conditions:

If at any time during the continuance of the Contract, the performance in whole or in part by either party of any obligation under this Contract shall be prevented or delayed by the reasons of any war, hostility, acts of the public enemy, epidemics, civil commotion, sabotage, fires, floods, explosion, quarantine restrictions, strikes, lockouts or act of God (but not including negligence or wrongdoing, predictable/seasonal rain) provided notice of happening of such event duly evidenced with documents is given by one party to the other within 10 days from the date of occurrence thereof, neither party shall be by reasons of such event, be entitled to terminate the Contract nor shall either party have any claim for damages against the other in respect of such

nonperformance or the delay in performance, and deliveries under the contract shall be resumed as soon as practicable after such event has come to an end or ceased to exist, and the decision of the Buyer as to whether the deliveries have been so resumed or not, shall be final and conclusive, Provided further that if the performance in whole or part of any obligation under this contract is prevented or delayed by reason of any such event for a period exceeding 90 days, either party may at its option terminate the contract provided also that the Buyer shall be at liberty to take over from the Seller at a price to be fixed by Buyer, which shall be final, all unused, undamaged and accepted material, bought out components and Goods in course of manufacture in the possession of the Seller at the time of such termination or such portion thereof as the Buyer may deem fit excepting such materials, bought out components and Goods as the Seller may with the concurrence of the Buyer elect to retain.

- Selected bidder shall have adequate manpower to execute the project successfully at IIM Raipur.
- Consortium/JV is not allowed in this bid.
- Bidders are to submit Unpriced BoQ along with Technical Compliance sheet in the technical Bid.
- Only bidders meeting the minimum criterion as defined above will be considered for further technical evaluation.
- Participating eligible bidders will be required to give a technical presentation to IIM Raipur of their offered solution during the course of technical evaluation as per the mutually agreed plan.
- The selected bidder will submit the detailed project plan within one week from the date of issuance of work order.

8. Bid Evaluation

For the purpose of selection of the bidder, a two bid system evaluation process will be followed. The response to the tender should be submitted in two parts viz. Technical Bid & Financial Bid. Evaluation will be done strictly on Eligibility Criteria and Technical Specification as mentioned in this tender.

The Technical Evaluation Committee constituted by the IIM Raipur shall verify the particulars furnished by the bidder independently and shall examine the bids to confirm that all documents pertaining to the Eligibility Criteria and Technical Criteria have been provided and shall ascertain the completeness of each document submitted. If any of these documents or information is missing, IIM Raipur reserves the right to call upon the missing documents/ Clarification on the submitted documents from the Bidders or reject the bid on account of unresponsive bid and the rejected bids will be ignored for the further evaluation purpose.

Only those bidders who fulfil the minimum eligibility criteria to participate in this bid will be considered for the further evaluation purpose i.e., Technical Scores Evaluation.

70% of weightage will be awarded for technical evaluation and 30% weightage will be awarded for financial evaluation.

Technical Score (Ts) will be assigned out of 100 marks as per the details given in Table below, only those bidders who score a minimum of 60 marks as per the below mentioned table will be considered for further evaluation of the financial bid.

The details submitted by the bidder will be evaluated in the following manner.

S.No.	Criterion	Marks				Max Marks (100)
1	Number of similar projects in last seven years		Min. No. of Projects	CFEI (Centrally Funded Educational Institutions)	Central / PSU / State	20
		Projects of value more than 10 Crores	1	10	7	
		Projects of value more than 7 Crores	2	5	3	
		Projects of value more than 5 Crores	3	3.5	2	
		Max Marks		20		
2	Average Annual Turnover	40 upto 45 Crore – 5 Marks ≥45 to 50 Crores – 8 Marks > 50 Crores – 10 Marks				10
3	Understanding of Project requirements	a. Integrated Project Management Plan covering the entire scope of work. (12 Marks) b. Project Plan covering areas including but not limited to (12 Marks): i. WBS (Work breakdown structure) ii. Activities, Timelines, Milestones and Deliverables iii. Site survey iv. Governance and RACI (Responsibility assignment Matrix) c. Risk Management Plan specially to manage project timelines and deliverables and business continuity plan (6 Marks).				30
4	Technical Presentation	The Technical Presentation should cover all the Project Components and the Bidders approach to successfully implement the same for Project duration				20
5	Technical Manpower	CVs of the Technical Manpower offered to be deployed on the project – Minimum 4 CVs * of resources including, Project Manager, Engineer, Resource to be posted on site. Engineer L3 - Specialist - 05 years of Experience (Marks 10) Server Engineer – Specialist – 03 years of Experience (Marks 6) Engineer L2 - Network & Monitoring - 02 Years of Experience				20

		(Marks 4) * This resource cannot be changed without written consent of IIM Raipur	
--	--	--	--

8.1 Final Selection and Award of Work

The Final Standing would be evaluated based on a composite score derived out of the technical evaluation and financial bid. The Financial Score (FS) shall be evaluated based on the financial offer from the shortlisted bidders.

After opening of the commercial bid proposals of the shortlisted bidders, the Lowest Financial proposal amongst all opened financial proposals shall be given a financial score (FS) of 100 marks.

The Financial Score (FS) of any other proposal will be determined using the following formula.

$$FS = 100 \times FL / F$$

Here, FL is the lowest financial proposal amongst all opened financial proposals and F is the financial proposal of the applicant whose FS is to be computed.

For the purpose of calculation of composite score (S) for each proposal, the weightage shall be 70% for Technical Evaluation Score (TE) and 30% for Financial Score (FS) of the respective bidders. The Composite Score (S) shall be calculated using the following formula.

$$S = 0.7 \times TE + 0.3 \times FS$$

Proposals will be ranked according to their composite scores (S) and, the top scorer H1 will be eligible for award of work. In case of a tie at the top position between two or more Finalists, the Finalist with higher Technical Score (TS) shall be given preference.

9. Delivery and Installation Conditions

At the destination site, the cartons will be opened only in the presence of IIM Raipur Officials and the vendor's representative. All delivery of items shall be signed with clear depiction of date on delivery note. Upon satisfactory installation of the equipment, vendor should obtain signed installation certificate from the official after making the stock entry at their end and specify the same in the installation certificate. Delivery notes and Installation certificate in original shall be submitted along with the bills by the vendor for payment.

For site not ready (SNR) case, vendor is required to submit a certificate, duly signed with date and stamp by the concerned officials. No Penalty will be levied for SNR cases; however, LD on late delivery shall be imposed. Vendor has to start installation work within 15 days of receipt of site ready notice from user and complete as per PO terms, failure on the same will invoke the penalty.

10. CAMC and Warranty Support for LAN Infrastructure

AMC and Warranty Support for LAN Infrastructure			
S. No.	Details	Passive Infrastructure	Active Infrastructure
1	CAMC and Warranty Support for all Infrastructure (which includes all elements installed in the network)	For a period of minimum 7 years after the completion of 1st year of normal warranty support from the date of acceptance. The support will include movement of nodes within a limited distance such as within a room.	For a period of minimum 3 years after the completion of 5th year of normal warranty support from the date of acceptance.
2	Movement LAN nodes other than existing room	Costing of cables/laying/and other infrastructure will be charged by the vendor (System Integrator) as per actual requirements of the site and will not be part of the current AMC and warranty support. The actual charges will be as per the rates discovered through this tender.	--
3	Comprehensive AMC Charges	SIs are required to quote comprehensive AMC charges (for installed passive infrastructure) based on number of LAN nodes in the network as per BOQ.	--
4	Change of Component/Equipment During AMC Period	SI is required to replace any failed components as per clause 2.5 (delivery and installation condition). If any equipment needs to be changed then bidder can change it with equal or higher make/ model with OEM concurrence.	If any equipment needs to be changed then bidder can change it with equal or higher make/ model with OEM concurrence.

11. Comprehensive Warranty and AMC Support Services & SLA:

- a) The warranty for active components would be valid for a period of 05 years from the date of final acceptance of the equipment by IIM Raipur or 63 months from the date of delivery to the consignee (in case delay in installation is on part of consignee), whichever is earlier. It will be under CAMC further for three years.
- b) The warranty for passive components would be valid for a period of 01 years from the date of final acceptance of the equipment by IIM Raipur or 15 months from the date of delivery to the consignee (in case delay in installation is on part of consignee), whichever is earlier. It will be under CAMC further for seven years.
- c) The bidder should have a centralized helpdesk for logging of complaints. After the call is logged, the complainant should receive a call back within 1 hour to brief the status of the call logged and the details of the engineer to whom the call is assigned, for efficient and quick resolution of the problem.
- d) There shall be a provision to log complaints/ open support cases directly with OEM on 24 x 7 basis through Phone/Email/Web for supplied equipment. Problems in equipment which causes downtime/degradation of services and resolution of which require development of patches, bug fixes etc. shall be treated by OEM on urgent basis. The OEM shall provide appropriate solution on fasttrack basis so that desired Service levels. The bidder shall furnish an undertaking from OEM in this regard.
- e) The vendor shall provide full details such as postal address/telephone no., email address, contact no. of Project Manager- Single Point of Contact (SPOC), Technical Expert and Field Engineer deputed for warranty/AMC support. Vendor to ensure that the manpower for Support is technically competent to expeditiously provide the support/ resolution of the issue(s) noted during Warranty & AMC period. The vendor shall deploy adequate technically competent manpower to carry out the awarded work as per the scope of work.
- f) The bidder shall be responsible for any defects (during warranty as well as AMC) that may develop under the conditions provided by the contract and under proper use, including arising from faulty materials, design or workmanship such as corrosion, inadequate quantity of material to meet equipment requirements, inadequate contact protection, in design etc. and/or otherwise and shall rectify such defects at his own cost when called upon to do so by the IIM.
- g) Bidder shall nominate an Account Manager / Senior functionary for day-to-day coordination with IIM throughout the warranty support service period.
- h) The Bidder should arrange to attend site at least once in six months by OEM/Authorized experts for preventive maintenance/Health checks/updates of equipment.
- i) The bidder shall provide Upgrades and Updates for all network & security equipment, software and hardware as and when released by OEMs and shall be made available free of cost. Software updates/upgrades shall also be done keeping in view advancement in technology, shortcomings of the system, security vulnerabilities, or changes required for improving functional efficiency and security level of the system. The bidder shall ensure complete rollback to original status in case of problem and shall take necessary system backups before the activity.
- j) All the patches installation and upgrades of network equipment are to be carried out by the bidder as per the recommendations and releases done by the OEM.

- k) Bidder shall ensure all latest updates/patches should be installed after replacement / reinstallation / maintenance activity of any device.
- l) All the equipment shall have on-site warranty and CAMC support i.e. the repair / replacement of faulty units during the warranty and AMC period has to be ensured at IIM Raipur campus after the complaint is lodged at the nearest customer support office.

11.1 Service Level Agreement(SLA)

The purpose of this Service Level Agreement (hereinafter referred to as SLA) is to clearly define the levels of service which shall be provided by the Selected Bidder to IIM Raipur for the duration of this Agreement. The selected Bidder shall regularly review the performance of the services being provided by the Selected Bidder and the effectiveness of this SLA.

11.2 Category of SLAs

This document provides for minimum level of services required as per contractual obligations based on performance indicators and measurements thereof. The Bidder shall ensure provisioning of all required services while monitoring the performance of the same to effectively comply with the performance levels. The services provided by the Bidder shall be reviewed by IIM Raipur as the following:

- a. Adherence to delivery schedule.
- b. Regularly check performance of the Bidder against this SLA.
- c. Obtain suggestions for changes to improving the service levels.
- d. Types of Incidents and requests
- e. Time to resolve and number of unclosed tickets.

11.3 Penalty for breach of SLA

S. No.	Activity	Rate
1	Failure in maintaining the delivery schedule	Any unjustified and unacceptable delay in delivery schedule will render the vendor liable for penalty at the rate of 0.1% (Zero-point one percent) per day to maximum 10% of the purchase order value whichever is lower after which the purchase order may be cancelled. Also, user holds the option to complete the delivery through alternate sources with extra cost of completion to be borne by the defaulting vendor.
2	Failure in maintaining the installation schedule	0.1% (Zero-point one percent) per day to maximum 10% of the purchase order value whichever is lower, thereafter IIM Raipur holds the option to complete the installation work through alternate sources with the extra cost of completion to be borne by the defaulting vendor.
3	Maintenance during warranty and AMC period	Under warranty and AMC support, penalty per day per equipment at the rate of 0.05% (Zero-point zero five percent) of the purchase value of the equipment if not repaired within 12/24/48 hours based on the call severity (defined in SLA Section). Maximum penalty will be limited to 10% (ten percent) of the purchase order value of the equipment. If system remains down beyond 30 days, IIM Raipur will have option to get it rectified through alternate source. The cost of repair on such default shall be recovered from the vendor outstanding payment or PBG.

4	Replacement of the faulty system	Any system, failing at subsystem level at least three times in three months, displaying chronic system design or manufacturing defects or Quality Control problem will be totally replaced by the Vendor at his cost and risk within 30 days, from the date of last failure. If supplier fails to replace the system within 30 days, penalty will be charged at the rate of 0.1% (Zero-point two percent) of system purchase value per day per system up to a maximum value of 10% (Ten percent) of the purchase order
---	----------------------------------	--

The penalty mentioned above will be deducted either from the quarterly payment or from the performance guarantee.

Operation and Maintenance Support goes through the following phases:

- a) Support Call Logging
- b) Support Call Resolution
- c) Support Call Closure

11.4 Escalation and Notifications:

The SI ensures that all the stakeholders are notified in a timely manner on the status of event/ticket. SI Service Desk system notifies users during following events:

1. Logging of ticket.
2. Status change of ticket.
3. Support engineers'-initiated notifications.

In order to ensure issues are resolved within SLA, Successful SI will have to use defined escalation mechanisms. Below is the standard Functional Escalation process followed for different severity calls. **Severity of calls will be defined by user based on the business impact on the system or equipment type.**

Severity of call	Type of call	Resolution time
Severity-1: Critical	Incident	12 Hours
Severity-2: Major	Incident	24 Hours
Severity-3: Minor	Incident	48 Hours

11.5 SLA Review Process

1. Either IIM Raipur or the selected Bidder may raise an issue, by documenting the business or technical problem, which presents a reasonably objective summary of both points of view and identifies specific points of disagreement with possible solutions.
2. A meeting or conference call will be conducted to resolve the issue in a timely manner. The documented issues will be distributed to the participants at least 24 hours prior to the discussion if the issue is not an emergency requiring immediate attention.
3. IIM Raipur and the selected Bidder shall develop an interim solution, if required, and subsequently permanent solution for the problem at hand. The selected Bidder will then communicate the resolution to all interested parties.
4. Penalties shall not be levied on the successful bidder in case of is a Force Majeure event affecting the SLA which is beyond the control of the successful bidder.

12. Acceptance Criteria for the Proposed Solution:

1. Coverage and Capacity Planning

- 1.1 On-site site survey by the bidder is required to plan LAN and Wi-Fi deployment in each floor of each building.
- 1.2. The bidder should provide the location of LAN and Access Points on the floor plan for all buildings.

2. Physical Installation:

- 2.1. Inspect installation of network racks, OFC laying, UTP cables, and network switches.
- 2.2. Configuration check on controller including the policies.
- 2.3. Test the physical mounting of each access point.
- 2.4. Test each access point connectivity to the wireless controller.

3. Wired Network Test

- 3.1. Perform OTDR tests for all OFC links and submit reports.
- 3.2. Perform end-to-end connectivity test of all UTP links and submit reports.
- 3.3. Check reachability and latency test on all network switches and submit reports.

4. Wi-Fi Controller Configuration Test:

- 4.1. Check authorized Wi-Fi set up for each subnet, VLAN, and location, as the case may be.
- 4.2. Check both authorized user and guest user policies.
- 4.3. Test each access point if it has the right authorized and guest policy.
- 4.4. Check Wi-Fi prevention policy for each subnet, VLAN, and location.
- 4.5. Check the configured alerts and alert delivery methods.
- 4.6. Check the administrative users and their access rights.
- 4.7. Check the configured reports (content, delivery frequency, recipient list).
- 4.8. Check the automatic backup and archival parameters.
- 4.9. Check archival of logs.

5. Commissioning Test:

- 5.1. Test for all access points connectivity to the wireless controller.
- 5.2. Test and verify authorized access points inventory and authorized client inventory.
- 5.3. Verify external access points list and verify uncategorized / unauthorized client list.
- 5.4. Verify if all authorized wireless devices are tagged to right location.
- 5.5. Test for authorized client connection to authorized access point and respective SSID as per the set authentication policy.
- 5.6. Test for guest client connection to authorized access points and respective SSID as per the set authentication policy.
- 5.7. Test if the access points are operational after shutting down the controller.
- 5.8. Test if automatic rogue access points prevention is working on all types of rogue APs.
- 5.9. Test if unauthorized client association to authorized access point is automatically prevented.
- 5.10. Test if automatic client Mis-association prevention is working.
- 5.11. Test if ad-hoc networks are detected and automatically prevented.

- 5.12. Test if MAC-spoofing is detected.
- 5.13 Test is Denial of Service (DoS) attack is detected.
- 5.14 Testing of deployment of policies, firmware updating remotely through the controller.
- 5.15 Testing WIPS functionality across the subnet.
- 5.16 The entire testing exercise should complete in stipulated time.

Documentation and Reports:

- 6.1. Documentation of the entire project along with testing reports must be submitted to IIM Raipur.
- 6.2. Documentation must include complete network diagram, which clearly depicts switch management IP Address, switch location, AP location, and switch port to each AP etc.
- 6.3. Documentation must include complete configuration in a step-by-step manner.

Intellectual Property Rights

All intellectual property rights for the work performed under this Tender as far as data is concerned shall lie with IIM Raipur. This clause is applicable to all data in any form or format designed and developed for IIM Raipur under this Tender by the vendor. The vendor shall not use such data for any other purpose during and after the term of contract.

Payment Terms

- i) 80% of the Product cost will be released at the time of delivery of equipment's after inspection, Installation and acceptance of the material at IIM Raipur campus and certification of receipt by stores in charge at IIM Raipur.
- ii) 10% of the product cost & 50% of the installation cost will be released on completion of installation and testing of the devices.
- iii) Balance 10% of the product cost & 50% of the installation cost will be released 03 months after the successful commissioning of complete network (active and passive), including submission of FAT Reports.
- iv) Warranty, AMC support and Manpower (based on MPR) bill payment will be released quarterly on prorated basis after deducting penalties due to SLA breach, if any.
- v) Payment will be released subject to deduction of TDS as per rules/laws prevalent at that time.

Performance Security / Performance Bank Guarantee (PBG):

The successful bidder must submit Performance Security / Performance Bank Guarantee (PBG) within two weeks of the issue date of the order. The PBG will be 5% of the total order value. The performance security must be valid for eight years and three months from the date of acceptance of successful installation by IIM Raipur. Performance security may be furnished in the form of Bank Guarantee issued by a scheduled commercial bank in India (preferably nationalized bank) in favor of "IIM RAIPUR" or payment through RTGS / NEFT in the following bank details:

Account Name: - IIM RAIPUR

Account No.-1292104000001052

Bank Name: - IDBI Bank

Branch: - IIM Raipur

IFSC Code:-IBKL0001292

No interest will be payable by IIM Raipur on the Performance Security deposited. The Earnest Money Deposit (EMD) of the successful bidder shall be returned on receipt of Performance Security (Performance Bank Guarantee / PBG).

13. Delivery Schedule

The project is to be completed within the overall proposed timelines of twenty (20) weeks. The activity wise timeline is as mentioned below:

S. No.	Measurement	Baseline Timeline (in Week) T= Date of issue of Purchase Order(PO)
1.	Start of shipment of Material Supply of CAT-6a & fiber cables, cable laying & Termination, passive components	T+6 weeks
2.	Delivery of Hardware/Equipment's Active Components: Switches, WLC, APs	T+12 weeks
3.	Installation, Configuration, Commissioning of all networking Hardware/ equipment's and Final acceptance test (FAT)	T+20 weeks
5.	Warranty and AMC support	Eight (8) Years from the date of FAT

14. CHECKLIST FOR BIDDERS TO BE SUBMITTED IN DULY FILLED AND SIGNED

Bid Sl. No.	Name of the Document	Document Particulars	Submitted (Yes/No)	Page No. of the attached Document
1.	PAN Card			
2.	Incorporation/Registration certificate of company			
3.	GST Registration copy			
4.	Company Registered Address and Contact Details			
5.	Tender acceptance letter			
6.	Non-Blacklisting undertaking			
7.	Experience Criteria (As per Annexure VII): The Bidder or its OEM {themselves or through reseller(s)} should have regularly, manufactured and supplied same or similar Category Products to any centrally funded educational institutions / Central or State Govt. Organization / Large Public Enterprise Companies for 7 years before the bid opening date. Copies of relevant contracts to be submitted along with bid in support of having supplied some quantity during each of the year. OEM offered must be present in India for at-least 15 years or more.			
8.	Bidder Turn Over Criteria (As per Annexure VI): The minimum average annual financial turnover of the bidder during the last three years, ending on 31st March of the previous financial year, should be 40 Crores as indicated in the bid document. Documentary evidence in the form of certified Audited Balance Sheets of relevant periods or a certificate from the Chartered Accountant / Cost Accountant indicating the turnover details for the relevant period shall be uploaded with the bid.			
9.	Compliance of OEM Criteria for Active Component			
10.	Compliance of OEM Criteria Pre-Qualification for Passive Component			
11.	The overall solution submitted by the bidder			

	should be a <u>Class-I/ Class-II</u> in line with the Public Procurement (Preference to Make in India) Order 2017 No. P-45021/2/2017-PP (BE-II) dated 04 Jun 2020. A Self-Declaration Certificate regarding " <u>Class-I/ Class-II/ Non-local suppliers</u> " for all the items along with %age of MII content to be submitted. %age of MII content should be supported by the declaration of OEM on his letter head.			
12.	The bidder should be either OEM or OEM authorized business partner / Channel partner / system integrator of reputed brand having authorization for sales and after sales support. Bid Specific MAF (Manufacturer Authorization Form) is required to participate in this tender.			
13.	Any bidder from a country which shares a land border with India will be eligible to bid in this tender only if the bidder registered with the competent authority. The concerned bidder(s) are required to attach the relevant valid Registration Certificate along with the bid for consideration.			
14.	Purchase Preference: (if applicable) Micro and Small Enterprises (MSEs):			
15.	Purchase Preference: Make in India			
16.	<p>Payment Terms:</p> <p>i) 80% of the Product cost will be released at the time of delivery of equipment's after inspection, Installation and acceptance of the material at IIM Raipur campus and certification of receipt by stores in charge at IIM Raipur.</p> <p>ii) 10% of the product cost & 50% of the installation cost will be released on completion of installation and testing of the devices.</p> <p>iii) Balance 10% of the product cost & 50% of the installation cost will be released 03 months after the successful commissioning of complete network (active and passive), including submission of FAT Reports.</p> <p>iv) Warranty, AMC support and Manpower (based on MPR) bill payment will be released quarterly on prorated basis after deducting penalties due to SLA breach, if any.</p>			

	v) Payment will be released subject to deduction of TDS as per rules/laws prevalent at that time.			
17.	Bid validity: 120 days from the date of opening of the tender.			
18.	Integrity pact to be submitted by bidder			
19.	Unpriced BoQ and Technical Compliance sheet			
20.	Specification Technical Compliance Statement			

Note:

The tender will lead to rejection/disqualification if submitted:

- 1) Submission of tender without the above-mentioned documents
- 2) It is mandatory for the bidder to assign page numbers to the tender documents and the same must be mentioned in the above checklist.
- 3) With incomplete information, subjective, conditional offers and partial offers submitted.
- 4) Have non-compliance of any of the clauses stipulated in the Tender.
- 5) With lesser validity period

Signature of the bidder with stamp

15. Annexures

Annexure-I**Particulars of the Bidder**

S. No.	Information Required	Details to be Furnished
1.	Name, address and URL of the bidding Company	
2.	Incorporation status of the firm (public limited / private limited, etc.)	
3.	Year of Establishment	
4.	Date of Registration	
5.	Details of company registration	
6.	GST Certificate	
7.	Average Turnover for the last 3 financial years	
8.	Name, Address, e-mail ID, Phone nos. and Mobile Number of Contact Person	

Compliance Declaration Sheet

We hereby confirm that we are complying with the technical specifications and Scope of Work as specified in the tender document without any deviation and the offer is submitted in accordance with the technical requirements. All relevant documents in support of our claims are enclosed at the following pages:

Signature of Bidder:

Name of Bidder:

Designation:

Organization Name:

Contact No.:

Email:

Mobile:

DECLARATION SHEET

(On Organization Letter Head)

Wehereby certify that all the information and data furnished by our organization with regard to this tender specification are true and complete to the best of our knowledge. I have gone through the specifications, conditions and stipulations in detail and agree to comply with the requirements and intent of specification.

We further certify that our organization meets all the conditions of eligibility criteria laid down in this tender document. Moreover, we will support the project on a regular basis with technology / product updates and extend support for the warranty.

We further specifically certify that our organization has not been Blacklisted/ De Listed or put to any Holiday by any Institutional Agency/ Govt. Department/ Public Sector Undertaking in the last three years	NAME & ADDRESS of the VENDOR/ MANUFACTURER
Phone	
E-mail	
Contact Person Name	
Contact Number	
TIN Number	
PAN Number	
In case of on-line payment of EMD) UTR No. (For EMD)	
Kindly provide bank details of the Bidder in the following format:	
a) Name of the Bank	
b) Account Number	
c) Kindly attach scanned copy of one Cheque book page to enable us to return the EMD to unsuccessful Bidder	

(Signature of the Bidder)**Name:****Seal of the Company**

Letter of Undertaking

(ON THE LETTER HEAD OF THE BIDDER)

To,

**The Director
Indian Institute of Management (IIM) Raipur
Atal Nagar P. O. - Kurru, Abhanpur,
Chhattisgarh 493661**

Sir/Madam,

SUBJECT: Selection of System Integrator for Supply, Installation, Testing & Commissioning of LAN Upgradation including network switches, passive cabling & Wi - Fi setup at IIM Raipur campus

This bears reference to IIM Raipur Bid No. Dated We hereby accept all the terms and conditions for submitting bid as mentioned in this Bid Document.

We hereby certify that no terms and conditions have been stipulated by us in the Financial Bid.

We warrant that the services do not violate or infringe upon any patent, copyright, trade secret or other property right of any other person or other entity. We agree that we shall not prevent IIM Raipur from any claim or demand, action or proceeding, directly or indirectly resulting from or arising out of any breach or alleged breach of any of the terms & conditions of bid document and contract.

The above document is executed on at (place) and we accept that if anything out of the information provided by us is found wrong, our bid/ work order shall be liable for rejection.

Thanking you,

Yours faithfully,

Signature of Bidder:

Name of the Bidder

Designation:

Seal of the Organization

Date:

Place:

Annexure V

SELF-DECLARATION – NON-BLACKLISTING

To,

The Director

Indian Institute of Management (IIM) Raipur

Atal Nagar P. O. - Kurru, Abhanpur,

Chhattisgarh 493661

Sir/Madam,

In response to the Tender dated for Selection of System Integrator for Supplying, Installation, Testing & Commissioning of LAN Upgradation including network switches , passive cabling & Wi - Fi setup at I IM Raipur campus, Chhattisgarh.

I/We hereby declare that presently our Company/Service provider M/s

is having unblemished record and is not blacklisted for corrupt or fraudulent practices or non- performance either indefinitely or for a particular period of time by any State/ Central Government/PSU/Autonomous Body on the date of bid submission.

If this declaration is found to be incorrect then without prejudice to any other action that may be taken, my/ our EMD may be forfeited in full and the tender if any, to the extent accepted be cancelled.

Thanking you

Yours faithfully

Signature of Bidder:

Name of the Bidder:

Designation:

Seal of the Organization:

Date:

Place:

Annexure VI

Annual Average Turnover

S. No.	Financial Year	Turnover	Net worth	Working Capital
1.	2020-21			
2.	2021-22			
3.	2022-23			
	TOTAL			
	AVERAGE			

Note: Certificate from Statutory Auditors / Chartered Accountant certifying above information for all three years to be enclosed.

Signature with Seal of the Chartered Accountant

Signature with Seal of the Bidder

Annexure-VII**Experience**

(only those works should be reported which are *similar in nature of works and were completed)

SN	Name of work/ project and location	Owner or sponsoring organization	Cost of *Similar Project in crores of rupees (Incl. GST)	Date of commencement as per Work	Stipulated date of completion of Work	Actual date of completion of Work	Name and address / telephone No. of officer to whom reference may be made
1							
2							
...							

*(add as many rows as needed)**(Supporting document to be attached)*

Signature of the bidder with seal and stamp

*'Similar Projects' is defined as, Supply, installation and maintenance of IT hardware & System Networking like network switches, wireless solution, LAN cabling, servers, network security devices.

**PROFORMA FOR DECLARATION ON PROCEEDINGS UNDER INSOLVENCY AND
BANKRUPTCY CODE, 2016**

Tender No. :

Name of Work:

Bidder's Name:

I/ We, M/s. _____ declare that: -

- a. I /We am / are not undergoing insolvency resolution Process or liquidation or bankruptcy proceeding as on date.
- b. I /We am / are undergoing insolvency resolution process or liquidation or bankruptcy proceeding as on date as per Details mentioned below. (Attached detail with technical bid)

Note: Strike out one of the above which is not applicable.

It is understood that if this declaration is found to be false, IIM Raipur shall have the right to reject my / our bid, and forfeit the EMD, if the bid has resulted in a contract, the contract will be liable for termination without prejudice to any other rights or remedies (including holiday listing) available to IIM Raipur.

Place:

Date:

Signature of
Bidder:

Name of Signatory:

PROFORMA PRE CONTRACT INTEGRITY PACT

GENERAL

This pre-bid pre-contract Agreement (hereinafter called the Integrity Pact) is made on _____ day of the month of 2024, between, on one hand, acting through Shri/Smt. _____, Designation, IIM Raipur (hereinafter called the “BUYER”/ “IIM Raipur” interchangeably, which expression shall mean and include, unless the context otherwise requires, his successors in office and assigns) of the First Part

AND

M/s _____ represented by _____, Authorized Signatory (hereinafter called the “Bidder/Seller” which expression shall mean and include, unless the context otherwise requires, his successors and permitted assigns) of the Second Part.

WHEREAS the IIM Raipur proposes to procure services towards **“Selection of System Integrator for Supplying, Installation, Testing & Commissioning of Campus Wide LAN upgradation (Both active & passive Equipment at IIM Raipur campus, Chhattisgarh)”**.

Bidder/Seller is willing to offer the said services and related items as referred to in the Bid document no. Dated..... 2024.

WHEREAS the Bidder is a private company /public company / Government undertaking / Partnership / Registered expert agency, constituted in accordance with the relevant law in the matter and the IIM Raipur is a higher education institution of national importance under Ministry of Education performing its functions.

NOW, THEREFORE,

To avoid all forms of corruption by following a system that is fair, transparent and free from any influence / prejudiced dealings prior to, during and subsequent to the currency of the contract to be entered into with a view to:

Enabling the IIM Raipur to obtain the desired services as referred to in the Bid Document No. dated2024 at a competitive price in conformity with the defined specifications by avoiding the high cost and the distortionary impact of corruption on public procurement and Enabling Bidders to abstain from bribing or indulging in any corrupt practice in order to secure the contract by providing assurance to them that their competitors will also abstain from bribing and other corrupt practices and the IIM Raipur will commit to prevent corruption, in any form, by its officials by following transparent procedures.

The parties hereby agree to enter into this Integrity Pact and agree as follows:

Commitments of the IIM Raipur

- The buyer undertakes that no official of the IIM Raipur, connected directly or indirectly with the contract, will demand, take a promise for or accept, directly or through intermediaries, any bribe, consideration, gift, reward, favor or any material or immaterial benefit or any other advantage from the Bidder, either for themselves or for any person, organization or third party related to the contract in exchange for an advantage in the bidding process, bid evaluation, contracting or implementation process related to the contract.
- The BUYER will, during the pre-contract stage, treat all Bidders alike, and will provide to all Bidders the same information and will not provide any such information to any particular Bidder which could afford an advantage to that particular Bidder in comparison to other Bidders.
- All the officials of the IIM Raipur will report to the appropriate Government office any attempted or completed breaches of the above commitments as well as any substantial suspicion of such a breach.
- In case any such preceding misconduct on the part of such official(s) is reported by the Bidder to the IIM Raipur with full and verifiable facts and the same is prima facie found to be correct by the IIM Raipur, necessary disciplinary proceedings, or any other action as deemed fit, including criminal proceedings shall be initiated by the IIM Raipur and such a person shall be debarred from further dealings related to the contract process. In such a case while an enquiry is being conducted by the IIM Raipur the proceedings under the contract would not be stalled.

Commitments of Bidders

- The Bidder commits itself to take all measures necessary to prevent corrupt practices, unfair means and illegal activities during any stage of its bid or during any pre-contract or post contract stage in order to secure the contract or in furtherance to secure it and in particular commit itself to the following:
- The Bidder will not offer, directly or through intermediaries, any bribe, gift, consideration, reward, favour, any material or immaterial benefit or other advantage, commission, fees, brokerage or inducement to any official of the IIM Raipur, connected directly or indirectly with the bidding process, or to any person, organization or third party related to the contract in exchange for any advantage in the bidding, evaluation, contracting and implementation of the contract.
- The Bidder further undertakes that it has not given, offered or promised to give, directly or indirectly any bribe, gift, consideration, reward, favor, any material or immaterial benefit or other advantage, commission, fees, brokerage or inducement to any official of the IIM Raipur or otherwise in procuring the Contract or forbearing to do or having done any act in relation to the obtaining or execution of the contract or any other contract with the Government for showing or forbearing to show favor or disfavor to any person in relation to the contract or any other contract with the Government.
- Bidders shall disclose the name and address of agents and representatives and Indian Bidders shall disclose their foreign principals or associates.

- Bidders shall disclose the payments to be made by them to agents/brokers or any other intermediary, in connection with this bid/contract.
- The Bidder further confirms and declares to the IIM Raipur that the Bidder is the original manufacturer/integrator/authorized government sponsored export entity and has not engaged any individual or firm or company whether Indian or foreign to intercede, facilitate or in any way to recommend to the IIM Raipur or any of its functionaries, whether officially or unofficially to the award to the contract to the Bidder, nor has any amount been paid, promised or intended to be paid to any such individual, firm or company in respect of any such intercession, facilitation or recommendation, as the case shall be for satisfactory performance of the proposed terms of Bidder.
- The Bidder will not collude with other parties interested in the contract to impair the transparency, fairness and progress of the bidding process, bid evaluation, contracting and implementation of the contract.
- The Bidder will not accept any advantage in exchange for any corrupt practice, unfair means and illegal activities.
- The Bidder shall not use improperly, for purposes of competition or personal gain, or pass on to others, any information provided by the IIM Raipur as part of the business relationship, regarding plans, technical proposals and business details, including information contained in any electronic data carrier. The Bidder also undertakes to exercise due and adequate care lest any such information is divulged.
- The Bidder commits to refrain from giving any complaint directly or through any other manner without supporting it with full and verifiable facts.
- The Bidder shall not instigate or cause to instigate any third person to commit any of the actions mentioned above.
- If the Bidder or any employee of the Bidder or any person acting on behalf of the Bidder, either directly or indirectly, is a relative of any of the officers of the IIM Raipur, or alternatively, if any relative of an officer of the IIM Raipur has financial interest / stake in the Bidder's firm, the same shall be disclosed by the Bidder at the time of filing of Bid.
- The Bidder shall not lend to or borrow any money from or enter into any monetary dealings or transactions, directly or indirectly, with any employee of IIM Raipur.

PREVIOUS TRANSGRESSION

The Bidder declares that no previous transgression occurred in the last three years immediately before signing of this integrity pact, with any other company in any country in respect of any corrupt practices envisaged hereunder or with any Public Sector Enterprise in India or any Government Department in India that could justify Bidder's exclusion from the bid process.

The Bidder agrees that if it makes incorrect statement on this subject. Bidder can be disqualified from the Bid process or the contract, if already awarded, can be terminated for such reason.

EARNEST MONEY DEPOSIT

No interest shall be payable by IIM Raipur to the Bidder on Earnest Money Deposit for the period of its currency.

SANCTIONS FOR VIOLATIONS

- i. Any breach of the aforesaid provisions by the Bidder or anyone employed by it or acting on its behalf (whether with or without the knowledge of the Bidder) shall entitle the IIM Raipur to take all or any one of the following actions, wherever required:
- ii. To immediately call off the pre-contract negotiations without assigning any reason or giving any compensation to the Bidder. However, the proceedings with the other Bidder(s) would continue.
- iii. The Earnest Money Deposit (in pre-contract stage) and/or Security Deposit /Performance Bond (Bank Guarantee) (after the contract is signed) shall stand forfeited either fully or partially, as decided by the IIM Raipur and the BUYER shall not be required to assign any reason, therefore.
- iv. To immediately, cancel the contract, if already signed, without giving any compensation to the Bidder.
- v. To encash the advance bank guarantee, if furnished by the Bidder, in order to recover the payments already made by IIM Raipur, along with interest.
- vi. To cancel all or any other Contracts with the Bidder. The Bidder shall be liable to pay compensation for any loss or damage to IIM Raipur resulting from such cancellation/rescission and IIM Raipur shall be entitled to deduct the amount so payable from the money(s) due to the Bidder.
- vii. To debar the Bidder from participating in future bidding processes of the Government of India for a minimum period of five years, which shall be further extended at the discretion of the IIM Raipur.
- viii. Forfeiture by way of encashment of Performance bank guarantee in case of a decision by the IIM Raipur to forfeit the same without assigning any reason for imposing sanction for violation of this Pact.
- ix. The decision of the IIM Raipur to the effect that a breach of the provisions of this Pact has been committed by the Bidder shall be final and conclusive on the Bidder. However, an Independent Monitor(s) shall be appointed by IIM Raipur, in case of breach of the provisions of the pact.

OTHER LEGAL ACTIONS

The actions stipulated in this Integrity Pact are without prejudice to any other legal action that shall follow in accordance with the provisions of the extant law in force relating to any civil or criminal proceedings.

VALIDITY

The validity of this Integrity Pact shall be governed by the terms of the Bid No..... towards complete execution of the contract to the satisfaction of both the IIM Raipur and the Bidder/Seller, including warranty period, whichever is later. In case the Bidder is unsuccessful, this Integrity Pact shall expire after six months from the date of the signing of the contract awarding the Bidder with successful Bidder.

Shall one or several provisions of this Pact turn out to be invalid; the remainder of this Pact shall remain valid. In this case, the parties will strive to come to an agreement to their original intentions.

The parties hereby sign this Integrity Pact at _____ on _____.

IIM Raipur

BIDDER

Name of the Officer:

Authorized Signatory

Designation: DIRECTOR

Designation:

Witness:

Witness:

1. _____

1. _____

2. _____

2. _____

Original Equipment Manufacturer (OEM) Authorization Form (General Proforma)

No. _____ dated _____

To,

Sir/Madam,

Bid No. _____

We _____ who are established and reputed manufacturer of _____ (name and description of goods offered) having factories at _____ (address of factory) with factory registration no.

----- do hereby authorize M/s _____ (Name and address of Bidder) to submit a bid, and sign the contract with you for the goods manufactured by us against the above bid.

We hereby extend our full warranty as per the required conditions of Contracts, for the goods and services offered for supply by the above firm against this Invitation for Bid. We further certify that we shall support vendor with all related spares and maintenance during the entire contract period including the period of warranty as per tender and we also declare that the product proposed in this contract will not be end of life till the contract period.

We undertake that we will support IIM Raipur directly or via another partner, if the bidder fails to fulfil their contractual obligations with respect to support during warranty or AMC period.

We also certify that the proposed products meet the technical & functional requirements & also products quoted are of the latest version.

Yours faithfully,

(Name): _____

(Name of manufacturers): _____

Note: This letter of authority should be on the letterhead of the manufacturer or OEM and should be signed by a person competent and having the power of attorney to legally bind the manufacturer.

Annexure XI**Pre-Bid Query Format**

Pre-bid queries should be submitted in .XLS format.

RFP Description				
RFP No.				
Organization				
Address				
Contact Person				
Contact No.				
Mail Id				
S.no.	Chapter No.	Page No.	Clause as per RFP	Clarification Sought

INSTALLATION CERTIFICATE

The following goods/equipment, supplied by the Supplier at IIM Raipur have been successfully installed and commissioned by the Supplier.

Sl. No.	Description of Equipment	Serial No of Device (Wherever possible)	Make	Model	Quantity
1					

Remarks:

Signature of Supplier or its representative:

Signature of IIM Raipur representative

Name:

Name:

Designation:

Designation:

Date:

Date

Rubber Seal:

Rubber Seal of the institution

Verified by NICS (PMC)

Signature:

Name:

Designation:

Date: __

Annexure XIII

Land Border Sharing Declaration

(To be submitted in the Bidder's Letter head)

I have read the clause regarding restrictions on procurement from a Bidder of a country which shares a land border with India and on sub-contracting to contractors from such countries.

I certify that this Bidder is not from such a country or, if from such a country, has been registered with the Competent Authority and will not sub-contract any work to a contractor from such countries unless such contractor is registered with the Competent Authority.

I hereby certify that this Bidder fulfils all requirements in this regard and is eligible to be considered.

[Where applicable, evidence of valid registration by the Competent Authority shall be attached.]”.

For and behalf of _____(Name of the Bidder)

(Signature, date & seal of authorized representative of the Bidder)

Annexure-XIV

Format of CV of key personnel proposed to be engaged in the project

(Please attach one sheet per key person)

1. Name:
2. Date of Birth and Age:
3. Position currently being held:
4. Role envisaged for the project:
5. Field specialization:
 - a. Key projects:
 - b. Role and actions performed (in each of the key projects):
6. Educational Qualifications*:

	Name of the degree	Year of graduation	University/Board	Marks or Grade Point (Overall)
Postgraduate Degree				
Undergraduate Degree				
Diploma				
Any Other (Pl specify)				

* A self-attested copy of each person's degree/Diploma certificate is to be provided by the bidder.

7. Professional Experience in years:
8. Remarks:

(Authorized Signatory)

FINANCIAL BID SUBMISSION FORM

To,

Dated: ___/___/2024

**The Director
Indian Institute of Management (IIM) Raipur
Atal Nagar P. O. - Kurru, Abhanpur,
Chhattisgarh 493661**

Dear Sir,

We, the undersigned, offer to provide **“Selection of System Integrator for Supplying, Installation, Testing & Commissioning of LAN Upgradation including network switches, passive cabling & Wi - Fi setup at IIM Raipur campus, Chhattisgarh”**.

In accordance with your request for proposal dated ___/___/2023 and certify that no terms and conditions have been stipulated by us in the Financial Bid.

Our attached Financial Bid is for the amount of *[Indicate the corresponding to the amount(s), currency (ies) {Insert amount(s) in words and figures}]*.

Please note that all amounts shall be the same as in the schedule of Rates. Our Financial Bid shall be binding upon by us subject to the modifications resulting from Contract negotiations, if any, up to expiration of the validity period of the Proposal.

Yours Sincerely,

Authorized Signature {In full and initials}:

Name and Title of Signatory:

In the capacity of:

Address:

E-mail:

FINANCIAL BID

Instructions to Bidders

1. Financial Bid shall be submitted with full price details.
Financial Bid shall contain only the prices duly filled in as per the format given in the Schedule of Rates provided in the tender document. Price bid should not have any Commercial and/or technical stipulation.
2. Financial Bid Standard form shall be used for the preparation of the price quote according to the instructions provided.
3. The prices quoted by the Bidder shall be fixed for the duration of the contract and shall not be subject to adjustment on any account.
4. The changes displayed in the corrigendum/addendum to the bid documents, particularly with the financial bid should be attached with the Financial Bid Submission Form, in the same packet, duly signed and stamped by the authorized signatory of the Bidder firm.
5. The financial bid should be filled in all respect and uploaded in “.PDF” format (only) duly signed and sealed by the authorized representative. In case the financial bid documents are not complete in all respects the same shall be treated as incomplete at financial bid opening stage and shall be considered non-responsive.
7. As per section 9, *extract is reproduced below:*

“...THE ABOVE BOQ IS INDICATIVE ONLY. ALL BIDDERS SHOULD CONDUCT A DETAILED SITE SURVEY OF THE CAMPUS AND UNDERSTAND THE REQUIREMENTS COMPLETELY BEFORE SUBMITTING THE TENDER. ANY ADDITIONAL REQUIREMENTS AT SITE TO ENSURE DELIVERY OF THE REQUIRED CAPABILITIES DEFINED ABOVE NEED TO BE CONSIDERED AND BIDDER SHOULD QUOTE ACCORDINGLY. ...”

Bidders are to provide Total Offered Solution Cost (TOSC) calculated based on their own rates as per Table A, Table B , Table C and Table D.

Table A- SCHEDULE OF RATES - Product Cost

S.No.	Description	Make & Model	UoM	Tentative Quantity	Unit Price (INR)	Total Price (INR)	GST (%)	GST (INR)	Total Price (INR)
1	2	3	4	5	6	7=(5*6)	8(a)	8(b)	9 = (7+8b)
1	Wi-Fi 6 Access Points 4x4 on 2.4 & 5 GHz – Type I		Nos.	275					
2	Wi-Fi 6 Access Points 4x4 on 2.4 & 5 GHz – Type II		Nos.	140					
3	WiFi6 Access Points 4x4 on 2.4GHz and 8x8 on 5GHz – Type III		Nos.	1					
4	Wireless LAN Controller (WLC) in HA		Nos.	2					
5	Core Switch 48-port in Stacking with redundant power supply Including 100GBASE-LR4 QSFP+ transceiver module for SMF		Nos.	2					
6	12 ports Layer-2 full PoE+ with 2x 10G SFP+ fixed uplinks		Nos.	8					
7	12 ports Layer-2 Non Poe (12-port 1G, 2x10G SFP+)		Nos.	17					
8	24 port Layer-2 PoE+ Access Switch with 24 X 10/100/1000 Mbps PoE+ ports & 4 X 1/10G SFP+ ports		Nos.	28					
9	24 ports Layer 2 Non PoE (24-port 1G, 4x 1/10G fixed uplinks)		Nos.	20					
10	48 ports Layer 2 Non PoE (24-port 1G, 4x 1/10G fixed uplinks)		Nos.	5					

RFP for up-gradation of Campus Wide Network at IIM, Raipur

11	48 ports Layer 2 PoE+ (48-port 1G, 4x 1/10G fixed uplinks		Nos.	8					
12	24 Port Layer 2 Multigigabit Switch (8 port mGig ports up to 10G, 16 ports up to 1G)		Nos.	9					
13	24 port mGig UPOE+ Switch, 24x 10G Multigigabit (10G/5G/2.5G/1G/100M)		Nos.	2					
14	48 port 5Gbps Multigigabit UPOE Switch (5G/2.5G/1G/100M)		Nos.	5					
15	Small form-factor pluggable transceiver - SM (SFP+)		Nos.	200					
16	NMS with hardware		Nos.	1					
17	Hardware with latest Windows Server edition for Domain Controller, DHCP, hypervisor etc.		Lot	1					
18	CAT6A UTP Cable Indoor (Box of 305 Meters)		Box	353					
19	CAT 6A UTP 12 Port Patch Panel Loaded		Nos.	27					
20	CAT 6A UTP 24 Port Patch Panel Loaded		Nos.	94					
21	CAT 6A UTP I/O with Face Plate & SMB		Nos.	1955					
22	CAT6A UTP Patch Cord-2 Meter		Nos.	1955					
23	CAT6A UTP Patch Cord-1 Meter		Nos.	1955					
24	24-Core Fibre Optic Outdoor Armoured cable		Mtrs.	14000					

RFP for up-gradation of Campus Wide Network at IIM, Raipur

25	06-Core Fibre Optic Outdoor Armoured cable		Mtrs.	500					
26	06-Core Fibre Optic Indoor Armoured cable		Mtrs.	3000					
27	12 port LIU,1U Rack mount enclosure LC-LC Fully loaded		Nos.	69					
28	24 port LIU,1U Rack mount enclosure LC-LC Fully loaded		Nos.	1					
29	48 port LIU,1U Rack mount enclosure LC-LC Fully loaded		Nos.	10					
30	Optical Fibre duplex Patch Cord, SM, LC-LC, Length 3 m		Nos.	210					
31	12U network Rack, Wall Mount		Nos.	56					
32	15U network Rack, Wall Mount		Nos.	14					
33	42U Network Rack, Floor Mount		Nos.	1					
34	Cable Manager 1U		Nos.	102					
35	HDPE Duct Pipe 33/40MM		Mtrs.	9000					
36	HDPE Duct Pipe 25MM		Mtrs.	1500					
37	G.I. Pipe 50MM with all accessories		Mtrs.	500					
38	25mm PVC Pipe		Mtrs.	8000					
39	40mm PVC Pipe		Mtrs.	4000					
40	25mm PVC Casing		Mtrs.	4000					
41	40 mm PVC Casing		Mtrs.	2000					
42	32mm PVC Flexible Pipe		Mtrs.	500					
43	32mm Armoured Flexible Pipe		Mtrs.	500					
44	OFC Route Marker		Nos.	250					

RFP for up-gradation of Campus Wide Network at IIM, Raipur

45	Outdoor OFC cable enclosure jointer		Nos.	15					
46	Miscellaneous items and accessories		Lot	1					
		A = Sum total of last column no. 9 i.e. Total Price							nnnnnnn

Table B - SCHEDULE OF SERVICE RATES - Active components Warranty and CAMC

S.No.	Description	Make & Model	UoM	Tentative Quantity	Unit - Five years warranty support Price (INR)	Unit - Three years CAMC support Price (INR)	Unit Price (INR)	Total Price (INR)	GST (%)	GST (INR)	Total Price (INR)
1	2	3	4	5	6(a)	6(b)	6=6(a)+6(b)	7=(5*6)	8(a)	8(b)	9 = (7+8b)
1	Wi-Fi 6 Access Points 4x4 on 2.4 & 5 GHz – Type I		Nos	275							
2	Wi-Fi 6 Access Points 4x4 on 2.4 & 5 GHz – Type II		Nos	140							
3	WiFi6 Access Points 4x4 on 2.4GHz and 8x8 on 5GHz – Type III		Nos	1							
4	Wireless LAN Controller (WLC) in HA		Nos	2							
5	Core Switch 48-port in Stacking with redundant power supply Including 100GBASE-LR4 QSFP+ transceiver module for SMF		Nos	2							
6	12 ports Layer-2 full PoE+ with 2x 10G SFP+ fixed uplinks		Nos	8							
7	12 ports Layer-2 Non Poe (12-port 1G, 2x10G SFP+)		Nos	17							
8	24 port Layer-2 PoE+ Access Switch with 24 X 10/100/1000 Mbps PoE+ ports & 4 X 1/10G SFP+ ports		Nos	28							

9	24 ports Layer 2 Non PoE (24-port 1G, 4x 1/10G fixed uplinks)		Nos	20								
10	48 ports Layer 2 Non PoE (24-port 1G, 4x 1/10G fixed uplinks)		Nos	5								
11	48 ports Layer 2 PoE+ (48-port 1G, 4x 1/10G fixed uplinks)		Nos	8								
12	24 Port Layer 2 Multigigabit Switch (8 port mGig ports up to 10G, 16 ports up to 1G)		Nos	9								
13	24 port mGig UPOE+ Switch, 24x 10G Multigigabit (10G/5G/2.5G/1G/100M)		Nos	2								
14	48 port 5Gbps Multigigabit UPOE Switch (5G/2.5G/1G/100M)		Nos	5								
15	Small form-factor pluggable transceiver - SM (SFP+)		Nos	200								
16	NMS with hardware		Nos	1								
17	Hardware with latest Windows Server edition for Domain Controller, DHCP, hypervisor etc.		Lot	1								
				B = Sum total of last column no. 9 i.e. Total Price								nnnnn nn

Table C - SCHEDULE OF SERVICE RATES - Passive components
Installation

S.No.	Description	Make & Model	UoM	Tentative Quantity	Unit Installation Price (INR)	Total Price (INR)	GST (%)	GST (INR)	Total Price (INR)
1	2	3	4	5	6	7=(5*6)	8(a)	8(b)	9 = (7+8b)
1	CAT6A UTP Cable Indoor (Box of 305 Meters)		Box	353					
2	CAT 6A UTP 12 Port Patch Panel Loaded		Nos.	27					
3	CAT 6A UTP 24 Port Patch Panel Loaded		Nos.	94					
4	CAT 6A UTP I/O with Face Plate & SMB		Nos.	1955					
5	CAT6A UTP Patch Cord-2 Meter		Nos.	1955					
6	CAT6A UTP Patch Cord-1 Meter		Nos.	1955					
7	24-Core Fibre Optic Outdoor Armoured cable		Mtrs.	14000					
8	06-Core Fibre Optic Outdoor Armoured cable		Mtrs.	500					
9	06-Core Fibre Optic Indoor Armoured cable		Mtrs.	3000					
10	12 port LIU,1U Rack mount enclosure LC-LC Fully loaded		Nos.	69					
11	24 port LIU,1U Rack mount enclosure LC-LC Fully loaded		Nos.	1					
12	48 port LIU,1U Rack mount enclosure LC-LC Fully loaded		Nos.	10					
13	Optical Fibre duplex Patch Cord, SM, LC-LC, Length 3 m		Nos.	210					

RFP for up-gradation of Campus Wide Network at IIM, Raipur

14	12U network Rack, Wall Mount		Nos.	56					
15	15U network Rack, Wall Mount		Nos.	14					
16	42U Network Rack, Floor Mount		Nos.	1					
17	Cable Manager 1U		Nos.	102					
18	HDPE Duct Pipe 33/40MM		Mtrs.	9000					
19	HDPE Duct Pipe 25MM		Mtrs.	1500					
20	G.I. Pipe 50MM with all accessories		Mtrs.	500					
21	25mm PVC Pipe		Mtrs.	8000					
22	40mm PVC Pipe		Mtrs.	4000					
23	25mm PVC Casing		Mtrs.	4000					
24	40 mm PVC Casing		Mtrs.	2000					
25	32mm PVC Flexible Pipe		Mtrs.	500					
26	32mm Armoured Flexible Pipe		Mtrs.	500					
27	OFC Route Marker		Nos.	250					
28	Outdoor OFC cable enclosure jointer		Nos.	15					
29	Miscellaneous items and accessories		Lot	1					
C = Sum total of last column no. 9 i.e. Total Price									nnnnnnn

The installation cost mentioned above includes expenses for tasks such as excavation, constructing chambers, laying charges, labor, and related activities as per standards. The work in accordance with the Government of India standards.

Table D - SCHEDULE OF SERVICE RATES - Manpower and CAMC of Nodes

S.No	Description Year of service UoM	Tentative Quantity	Technical manpower charges for One year (INR)	Total Price (INR)	GST (%)	GST (INR)	Total Price (INR)
1	2	3	4	5=(3*4)	6(a)	6(b)	7 = (5+6b)
1	Engineer L3 - Specialist - 05 years of Experience	1					
2	Engineer Server Engineer - 03 Years of Experience	1					
3	Engineer L2 - Network & Monitoring - 02 Years of Experience	1					
4	Comprehensive Annual Maintenance cost of all nodes per year	7 Year					
D = Sum total of last column no. 9 i.e. Total Price							nnnnnnn

* The Increment for the Manpower (item no. 1,2,3) will be 5-10% on Yearly basis after completion of one year based on the performance evaluation.

Financial Bid Value – Grand Total Value (GTV):

S.no.	Description	Value	Weightage in GTV	Contribution of Value in GTV
1	1	2	3	4 = 2*3
1	SCHEDULE OF RATES - Product Cost	<i>Value of A from table A</i>	80%	NNN
2	SCHEDULE OF SERVICE RATES - Active components Warranty and CAMC	<i>Value of B from table B</i>	20%	NNN
3	SCHEDULE OF SERVICE RATES - Passive components Installation	<i>Value of C from table C</i>	40%	NNN
4	SCHEDULE OF SERVICE RATES - Manpower and CAMC of Nodes	<i>Value of D from table D</i>	100%	NNN
Grand Total Value(GTV) – Sum total of column 4				NNNNNNNNNNNN

GTV in Words: _____

Annexure XVI

Undertaking for category by the Bidder (Certified by Cost Auditor)

(To be submitted by bidder)

This is to confirm that the information mentioned below is in compliance with the Order No. P-45021/2/2017-PP (BE - II), Ministry of Commerce & Industries (DPIIT) dt. 4th June 2020 and is correct to the best of my knowledge. I also provide consent to IIM Raipur to validate our claim at any point of time. The bid shall be rejected, and Security Deposit will be forfeited, in case any discrepancies / any information/ data provided by me in this regard found to be false / incorrect / misleading.

S. No	Particulars	Details <i>(to be filled by the Bidder/ OEM/Supplier)</i>
I	OEM Category	
a.	Category – I Local Supplier	
b.	Category – II Local Supplier	
c.	Non – Local Supplier	

Authorized Signatory:

Date:

Name & Designation:

Place:

INSTRUCTIONS OF ONLINE BID SUBMISSION

Instructions to the Bidders to submit the bids online through the Central Public Procurement Portal for e Procurement at <http://eprocure.gov.in/eprocure/app>.

1. Possession of valid Digital Signature Certificate (DSC) and enrollment/registration of the contractors/bidders on the e-Procurement/e-RFP portal is a prerequisite for e-tendering.
2. Bidder should do the enrollment in the e-Procurement site using the "Online Bidder Enrollment" option available on the home page. Portal enrollment is generally free of charge. During enrollment/registration, the bidders should provide the correct/true information including valid email id. All the correspondence shall be made directly with the contractor/bidders through email id provided.
3. Bidder need to login to the site through their user I.D./ password chosen during enrollment/registration.
4. Then the Digital Signature Certificate (Class II or Class III Certificates with signing key usage) issued by SIFY/TCS/nCode/eMudra or any Certifying Authority recognized by CCA India on eToken/SmartCard, should be registered.
5. The DSC that is registered only should be used by the bidder and should ensure safety of the same.
6. Contractor/Bidder may go through the RFPs published on the site and download the required RFP documents/schedules for the RFPs he/she is interested.
7. After downloading / getting the RFP document/schedules, the Bidder should go through them carefully and then submit the documents as asked, otherwise bid will be rejected.
8. If there are any clarifications, this may be obtained online through the RFP site, or through the contact details. Bidder should take into account the corrigendum published before submitting the bids online.
9. Bidder then logs in to the site through the secured log in by giving the user id/ password chosen during enrolment/registration and then by giving the password of e-Token/Smartcard to access DSC.
10. Bidder selects the RFP which he/she is interested in by using the search option & then moves it to the 'my RFPs' folder.
11. From my RFP folder, he selects the RFP to view all the details indicated.

12. It is construed that the bidder has read all the terms and conditions before submitting their offer. Bidder should go through the RFP schedules carefully and upload the documents as asked; otherwise, the bid will be rejected.
13. Bidder, in advance, should get ready the bid documents to be submitted as indicated in the RFP documents/schedule and generally, they can be in PDF/xls/rar/jpg/dwf formats. If there is more than one document, they can be clubbed together and can be provided in the requested format. Bidders Bid documents may be scanned with 100 dpi with black and white option. It is advisable that each document to be uploaded through online for the RFPs should be less than 2 M.B. If any document is more than 2 M.B., it can be reduced through rar and the same can be uploaded, if permitted. However, if the file size is less than 1 MB the transaction uploading time will be very fast.
14. If there are any clarifications, this may be obtained through the site. Bidder should take into account the corrigendum published from time to time before submitting the online bids.
15. The Bidders can update well in advance, the documents such as certificates, annual report details etc., under My Space option and these can be selected as per RFP requirements and then send along with bid documents during bid submission. This will facilitate the bid submission process faster by reducing upload time of bids.
16. Bidder should submit the RFP Fee/EMD as specified in the RFP. The original should be posted/couriered/given in person to the RFP Inviting Authority, within the bid submission due date & time for the RFP or as indicated in the RFP. Scanned copy of the instrument should be uploaded as part of the offer.
17. While submitting the bids online, the bidder reads the terms & conditions and accepts the same to proceed further to submit the bid packets.
18. The bidder has to select the payment option as offline to pay the RFP Fee/EMD as applicable and enter details of the instruments.
19. The details of the D.D./ any other accepted instrument, physically sent, should tally with the details available in the scanned copy and the data entered during bid submission time. Otherwise submitted bid will not be acceptable or liable for rejection.
20. The bidder has to digitally sign and upload the required bid documents one by one as indicated. Bidders to note that the very act of using DSC for downloading the bids and uploading their offers shall be deemed to be a confirmation that they have read all sections and pages of the bid document including General conditions of contract without any exception and have understood the entire document and are clear about the requirements of the RFP requirements.
21. The bidder has to upload the relevant files required as indicated in the cover content. In case of any irrelevant files, the bid will be rejected.

22. If the price bid format is provided in a spread sheet file like BoQ_xxxx.xls, the rates offered should be entered in the allotted space only and uploaded after filling the relevant columns. The Price-bid BOQ template must not be modified/replaced by the bidder; else the bid submitted is liable to be rejected for this RFP.
23. The bidders are requested to submit the bids through online e-tendering system to the RFP Inviting Authority (TIA) well before the bid submission end date & time (as per Server System Clock). The TIA will not be held responsible for any sort of delay or the difficulties faced during the submission of bid online by the bidders at the eleventh hour.
24. After the bid submission (i.e. after Clicking "Freeze Bid Submission" in the portal), the acknowledgement number, given by the system should be printed by the bidder and kept as a record of evidence for online submission of bid for the particular RFP and will also act as an entry pass to participate in the bid opening date.
25. The time settings fixed in the server side & displayed at the top of the RFP site, will be valid for all actions of requesting, bid submission, bid opening etc., in the e-RFP system. The bidders should follow this time during bid submission.
26. All the data being entered by the bidders would be encrypted using P.K.! encryption techniques to ensure the secrecy of the data. The data entered will not be viewable by unauthorized persons during bid submission & not be viewable by any one until the time of bid opening.
27. Any bid document that is uploaded to the server is subjected to symmetric encryption using a system generated symmetric key. Further this key is subjected to asymmetric encryption using buyers/bid openers' public keys. Overall, the uploaded RFP documents become readable only after the RFP opening by the authorized bid openers.
28. The confidentiality of the bids is maintained since the secured Socket Layer 128 bit encryption technology is used. Data storage encryption of sensitive fields is done.
29. The bidder should logout of the tendering system using the normal logout option available at the top right hand corner and not by selecting the (X) exit option in the browser.
30. For any queries regarding e-tendering process, the bidders are requested to contact as provided in the RFP document. Parallely for any further queries, the bidders are asked to contact over phone: 0120-4001 002 or send a mail over to cppp-nic@nic.in.